



Instruction Manual

Albin AOFD Pump**

Air Operated Floating Diaphragm Pumps
(AD Series / ** Patented)

Read and understand this manual before to operate or servicing this product.
IM-AD/09.03 EN (2010/02)

Declaration of conformity

(Directive 98/37/EG, Annex IIA)



Manufacturer

Albin Pump AB
Ålegårdsgatan 1
SE-431 50 Mölndal
Sweden

We declare under our sole responsibility that the product:

Albin AD

Air Operated Diaphragm Pumps

Type: AD15, AD30, AD60, AD120

are in conformity with COUNCIL DIRECTIVE on the approximation of the laws of the Member States relating to Machinery 98/37/EG.

Declaration of incorporation

(Directive 98/37/EG, Annex IIB)

AD, Air Operated Diaphragm Pumps, must not be put into service until the machinery into which it is to be incorporated has been declared in conformity with the provisions of the Directive.

Mölndal, Sweden, 02.05.2006

Christian Söderholm
Managing director

Index

1.0 Introduction	5
1.1 General	5
1.2 Reception and storage	5
1.2.1 Reception	5
1.2.2 Storage	5
1.3 Safety	6
1.4 Operating principle	8
1.4.1 Operating principle for the AD pump	8
1.5 Model specification	9
1.6 Standard parts	9
2.0 Technical information	10
2.1 Technical data	10
2.2 Material specification	10
2.3 Temperature limitations	12
2.4 Sound level ratings	12
2.5 Dry running	12
2.6 Rest volumes	12
3.0 Pump performance curves	13
3.1 Nominal capacity AD range	13
3.2 How to use the performance curves	14
3.2.1 Reduction for viscosity - AD15 - AD120	15
3.2.2 Reduction for suction lift - AD15 - AD120	15
3.3 AD15 16 3.4 AD30	17
3.4 AD60	18
3.5 AD120	19

Index

4.0 Installation	20
4.1 System design and installation	21
4.2 Suggested pump installation	22
4.3 Venting exhaust air	22
4.4 Before starting the pump	22
4.5 How to start, operate and stop the pump	23
4.6 Routine maintenance	23
5.0 Directions for disassembly and reassembly	24
5.1 Disassembly	24
5.1.1 Diaphragms	24
5.1.2 Check valves, shaft, spring and shaft bushing	25
5.1.3 Covers and air distribution mechanism	25
5.1.4 Air motor and manifolds	26
5.2 Resassembly	26
5.2.1 Air motor and manifolds	26
5.2.2 Covers and air distribution mechanism	27
5.2.3 Shaft, shaft bushing, shaft spring and check valves	27
5.2.4 Air motor and manifolds	28
5.2.5 Air motor	28
6.0 Dimensions and weights	29
7.0 Exploded views and Part lists	30
7.1 Pump	31
7.2 Air motor spare parts	32
7.3 Spare part kits	33
8.0 Trouble shooting	35



1.0 Introduction

1.1 General

The air operated diaphragm pump series AD is manufactured by Albin Pump and is marketed and sold by a net of authorised distributors.

This instruction manual contains important information on the AD range and must be read carefully before installation, service and maintenance. The manual must be kept easily accessible to the operator.

Important!

The pump must not be used for other purposes than recommended and quoted for without consulting the Albin Pump distributor.

 Liquids not suitable for the pump can cause damages to the pump unit and imply risk of serious personal injury.

1.2 Reception and storage

1.2.1 Reception

Remove all packing materials immediately after reception. Check the consignment for damage at once and make sure that the name plate/type designation is in accordance with the packing slip and your order.

In case of damage and/or missing parts a report should be drawn up and presented to the carrier instantly. Notify your Albin Pump distributor.

All pumps have the type specification (Type) printed on the name plate which is located on the pump housing above the inlet port. This specification should always be quoted in all correspondence with your distributor.

The model specification (Type) describes the pump materials and options – see section 1.5

The manufacturing date (Mfg. date), e.g. 090128 states year, month and day of manufacturing.



The serial number (Mfg. No.) is a consecutive number registered at Albin Pump. The arrow on the name plate shows the flow direction.

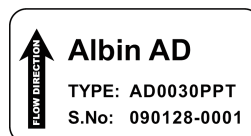

1.2.2 Storage

If the pump is not installed immediately it is recommended to store it in a dry, clean and cool location. The pump is tested with compressed air in a completely dry condition so there is no liquid left in the pump.





1.3 Safety

Important!

The pump must not be used for other purposes than recommended and quoted for without consulting your Albin Pump distributor.

 Liquids not suitable for the pump can cause damages to the pump unit and imply risk of serious personal injury. Always consult your Albin Pump distributor if you are not sure of the compatibility of fluids with the pump materials including the elastomers.

 **HAZARD WARNING - POSSIBLE EXPLOSION HAZARD** can result if 1, 1, 1-Trichloro ethane, Methylene Chloride or other Halogenated Hydrocarbon Solvents are used in pressurized fluid systems having Aluminium wetted parts. Death, serious bodily injury and/or property damage could result.

 The pump must always be installed and used in accordance with existing local and national sanitary and safety regulations and laws.

 The pump can create fluid pressures equal to the air supply pressure. Do not exceed the maximum permissible air supply pressure of 7 bar. The total hydraulic pressure (system pressure + differential pressure) must never exceed 7 bar.

 Do not exceed the recommended operating temperatures of the pump. The maximum temperature limitations are based on mechanical stress only and various liquids/chemicals may reduce the maximum safe operating temperatures of the pumps.

Diaphragms: PTFE can operate continuously between -30°C and +85°C.

Pump housing: PP (polypropylene) can be used in the interval $\pm 0^{\circ}\text{C}$ and +85 °C.
Aluminium can be used in the same interval as the diaphragms.

 Inside the pump two diaphragms are separating the pumped liquid from the air supply. When a diaphragm ruptures fluid may be expelled through the air exhaust port. If dangerous liquids are handled always connect the air exhaust port with a suitable container in a safe location. When the product source is at a higher level than the pump (flooded suction), the exhaust should be piped to a higher level than the product to prevent spills caused by siphoning.

 Never operate a pump that is leaking, damaged, corroded or otherwise unable to contain the internal fluid or air pressure.

 Never exceed the recommended service and inspection intervals for the diaphragms and air motor parts.

 Never put your face or body near the pump air exhaust while the pump is operating. Always shut off the air supply and disconnect it from the pump before making repairs to the pump. Be sure to relief all pressure from the discharge and suction pipes/hoses prior to disconnecting the pump from the system.













 Static electricity can be created when the pump is operating. Always use conductive polypropylene pumps in hazardous environments or for flammable fluids. Pumps must be properly grounded. Strictly follow the local safety regulations for hazardous environments.



Safety

Important!

The pump must not be used for other purposes than recommended and quoted for without consulting your Albin Pump distributor.

-  Never use, under no circumstances, the pumps for pumping non-conductive flammable or explosive fluids.
-  The AOFD pumps do not exceed a noise level rating of 80 dB(A) but still it is advised always to wear ear protection when you are working or standing close to an operating AODD pump. Noise can be substantially reduced by leading the exhaust air away through a hose connected to the air exhaust port.
-  Always wear suitable safety clothing when handling the pump.
-  Install shut-off valves on both side of the pump to be able to shut off the in- and outlet before service and maintenance. Check to see that the pump can be drained without injuring anyone and without damaging the environment or nearby equipment.
-  Always install a separate shut-off valve for the air supply easily accessible for manoeuvring.
-  Pressure variations may cause vibrations in the piping systems. Connect the pump to the pipes via flexible coupling/hoses. Ensure that the pipes/fittings are securely bolted to the foundation.
-  Improper installation can cause fatal injuries.
-  If the pump handles liquids hazardous for person or environment, some sort of collector must be installed into which leakage can be led.
-  If the surface temperature of the system or parts of the system exceeds 60°C, these areas must be marked with warning text reading "Hot surface" to avoid burns.
-  Never use other compressed gases than air to operate the pump.
-  Before starting the pump always make sure that the discharge point of the piping system is clear and safe and that all persons have been warned to stand clear.
-  Always check the flow direction prior to start-up.

1.4 Operating principle

The AOFD pump is an air-powered, reciprocating positive displacement pump with two pumping chambers. Two diaphragms, centrally located in the chambers, separate the compressed air (“dry side”) from the liquid being pumped (“wet side”). A shaft connects the two diaphragms to each other.

A valve (air motor) distributes the air from one chamber to the other alternately, thus a reciprocating movement of the diaphragms is created. At each stroke liquid is displaced by one of the diaphragms while the opposite diaphragm sucks new liquid into the expanding chamber. Check valves, two on the discharge side and two on the suction side, control and direct the liquid flow.

1.4.1 Operating principle for the AOFD pump

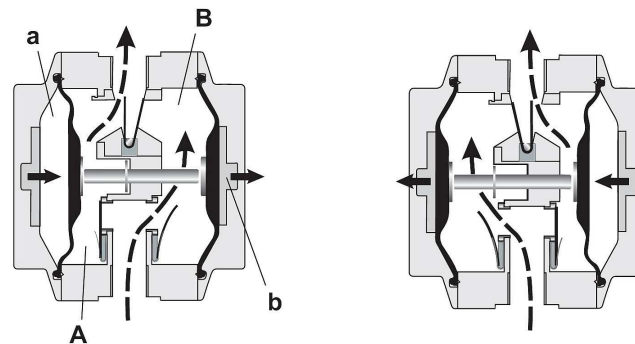

Compressed air enters the air chamber (a) on the left side of the pump. The diaphragms are pushed to the right and liquid is displaced from chamber (A). Simultaneously pressure is reduced in chamber (B) and new liquid enters. Used air is pushed out from the right air chamber (b).

Note the short flow path through the centre of the pump and how the check valves are opening and closing.

In the AOFD pump the diaphragms are not fixed to the shaft. Thanks to this Flexible Diaphragm Suspension (FDS-invention) and the spring at the shaft end, the diaphragms can move a short distance independently of each other. At the end of each stroke both diaphragms are exposed to compressed air for a very short period. When the left diaphragm has come to the end position, the right one has already started to move back to the left and the spring is compressed. Thereafter the left diaphragm starts to move to the left and the spring expands.

The two diaphragms are overlapping each other and thus there is no complete dead end at the same moment - pulsation is reduced.

This operating principle requires an extremely short reversing time of the compressed air. The traditional sliding air valve could not be used and a new low friction air motor (FPV-invention -Frictionless Pivoting Valve) with a rocking motion was developed. The new air motor is nothing less than a patented sensation - extremely simple with very few parts and completely insensitive to the quality of the compressed air.

The cycle is completed and the two diaphragms are now moving back to the left.

1.5 Model specification

Example: AD 0015 PX T

1. **Family name**
AD
2. **Pump size**
15, 30, 60, 120
3. **Pump housing material**
AL = Aluminium
AX = Aluminium Atex (EX)
PP = Polypropylene
PX = Polypropylene Conductive Atex (EX)
SS = Stainless Steel 316L
4. **Diaphragm material**
T = TEFLON (PTFE with nitrile carrier)

1.6 Main standard parts

- | | | |
|------------------------------------|--------------------------------|-------------------------|
| (1) Pump housing | (30) Insert Inlet | (6) Checkvalve Retainer |
| (4) Lid | (29) CEG lockring Inlet | (24) Foot plate |
| (5) Diaphragm | (33) Air motor gasket external | (3) Cap nuts |
| (27) Air motor | (28) Muffler Standard | (32) Hexagon screws |
| (15) Pilot valve | (31) CEG lockring Outlet | |
| (16) Pilot valve spring (optional) | (7) Checkvalve Inlet | |
| (14) Pilot valve bushing | (12) Checkvalve Outlet | |

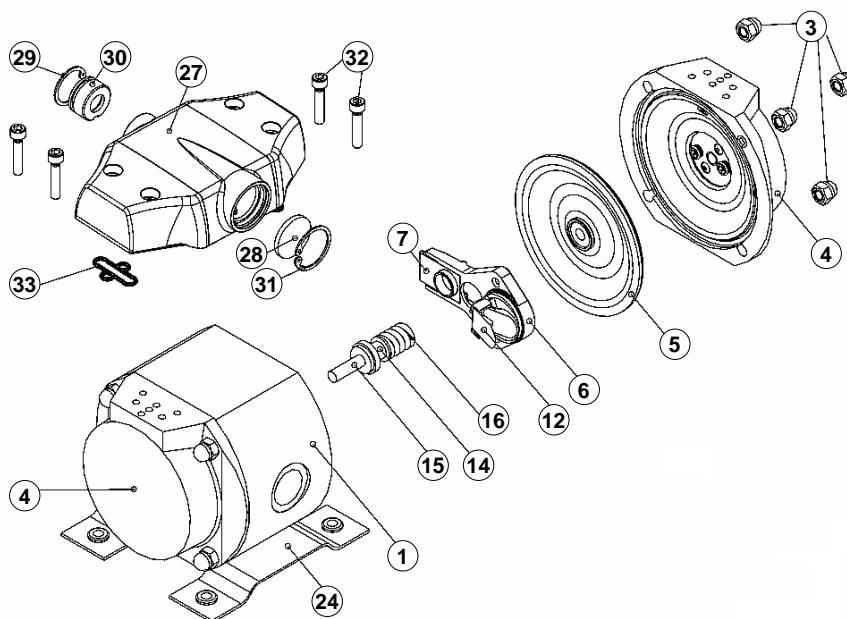



2.0 Technical information

2.1 Technical data

Size	15	30	60	120
Port size	1/4"	3/8"	3/4"	1.1/4"
Nominal max capacity (l/min)	20	35	80	130
Max pump pressure (bar)	7	7	7	7
Max air pressure (bar)	7	7	7	7
Max suction lift dry (m)	3	3	5	5
Max suction lift wet (m)	8	8	8	8
Max size of solids (mm)	4	4	5	5
Weight, version PP/Al (kg)	2.5 / 3.7	2.5 / 3.7	3.6 / 4.9	6.9 / 9.8

2.2 Material specification

Wetted parts	Material	AISI	DIN
Pump housing	PP (Polypropylene) or Aluminium	(AA6082) *	3.2315
Shaft bushing	PPS (Tedur) 40% glass		
Shaft	Stainless steel	316	1.4436
Spring	Stainless steel	316	1.4401
Check valve retainer 30 / 60	PPS (Tedur) 40% glass		
Check valve retainer 120	Stainless steel	316	1.4436
Check valve (in- and out)	PEEK		
O-ring	Teflon (PTFE)		
Screw	Stainless steel	316	1.4436
Nut	Stainless steel	316	1.4436
Diaphragm	Teflon (PTFE)		
Diaphragm plate	Stainless steel	316	1.4436

N.B. The comparison of standards is not 100% correct but is the closest possible from each standard.

**) AA is a standard published by the Aluminum Association. The standard follows the "Registration Record of International Alloy Designations".*



2.2 Material specification (cont'd)

Size	Material	AISI	DIN	SS
Air outlet seal	NBR (nitrile)			
Diaphragm	EPDM			
Diaphragm plate	Stainless steel	316	1.4436	2343
Washer	PA polyamide			
Side cover	Aluminium	not known	not known	4253
Plunge	PA polyamide			
Ball seat	PA polyamide			
Ball	NBR (nitrile)			
Air motor housing	Aluminium	(AA6082)*	3.2315	4212
Cover	Aluminium	(AA6082)*	3.2315	4212
Air connection	Aluminium	(AA6082)*	3.2315	4212
Air manifold	Aluminium	(AA6082)*	3.2315	4212
Motor pivot	Stainless steel	303	1.4305	2346
Pivot air seals in- and outlet	NBR/ Stainless steel	304	1.4301	2332
Air gaskets	NBR (nitrile)			
Muffler	HDPE (polyethylene)			
Air O-rings	NBR (nitrile)			

N.B. The comparison of standards is not 100% correct but is the closest possible from each standard.

**) AA is a standard published by the Aluminum Association. The standard follows the "Registration Record of International Alloy Designations".*

Externals	Material	AISI	DIN	SS
Foot plate	Stainless steel	304	1.4301	2333
Rubber foot	NBR (nitrile)			
Screw	Stainless steel	304	1.4301	2333
Stud bolt	Stainless steel	304	1.4301	2333
Cap nut	Stainless steel	304	1.4301	2333
Screw	Stainless steel	304	1.4301	2333

N.B. The comparison of standards is not 100% correct but is the closest possible from each standard.



2.3 Temperature limitations

Do not exceed the recommended operating temperatures of the pump. The maximum temperature limitations are based on mechanical stress only and various liquids/chemicals may reduce the maximum safe operating temperatures of the pumps.

Diaphragms: PTFE can operate continuously between -30°C and +85°C.

Pump housing: PP (polypropylene) can be used in the interval $\pm 0^{\circ}\text{C}$ and +85°C.
Aluminium can be used in the same interval as the diaphragms.

2.4 Sound level ratings

The following values were measured from an type AD 60, pumping water at 7 bar air pressure and fully open inlet and discharge ports. The readings were made at a distance of 1 (one) metre on the same level as the pump:

- Front 79.5 dB(A)
- Left 75.5 dB(A)
- Right 74.9 dB(A)
- Behind 72.6 dB(A)

2.5 Dry running

The AOFD pump can normally run dry without damaging the pump components. For extended periods of dry running, however, a certain wear of the shaft bushing will occur.

2.6 Rest volumes

If the pump runs until it has emptied the suction line the following rest volumes will remain in the pumps:

- AD15 45 ml
- AD30 45 ml
- AD60 90 ml
- AD120 200 ml

If the product discharge line is closed the following volumes will remain in the pump:

- AD15 90 ml
- AD30 90 ml
- AD60 180 ml
- AD120 400 ml



3.0 Pump performance curves

N.B. All curves are based on water discharge capacity at 20°C at 0 m suction head.

- To compensate for higher viscosity use the curve “3.2.1 Reduction for viscosity”.
- To compensate for a negative suction head use the curve “3.2.2 Reduction for suction lift”.

Important - to obtain a long diaphragm life and a high efficiency (low air consumption) always select a pump which has a max capacity which is as least 1,5 times higher than the desired flow rate.

Caution - do not exceed 7 bar air supply or liquid pump pressure.

3.1 Nominal capacity AD range

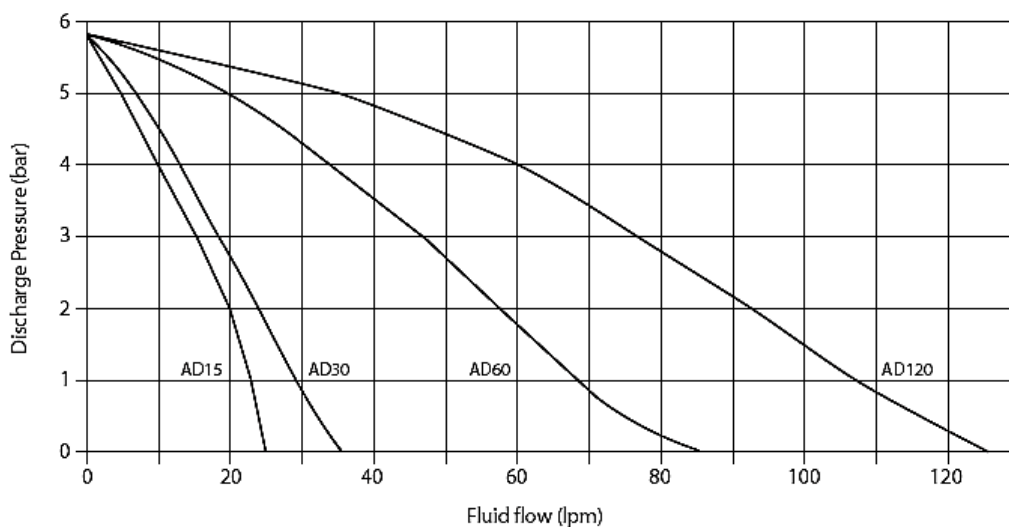

3.2 How to use the performance curves

Example: AD60 - 30 l/minute against a discharge pressure of 2.0 bar.

Pump selection

Find the required flow (30 l/min) along the horizontal axis. Go vertical to the intersection with 2 bar fluid outlet and read the air pressure required, ~ 3,5 bar.

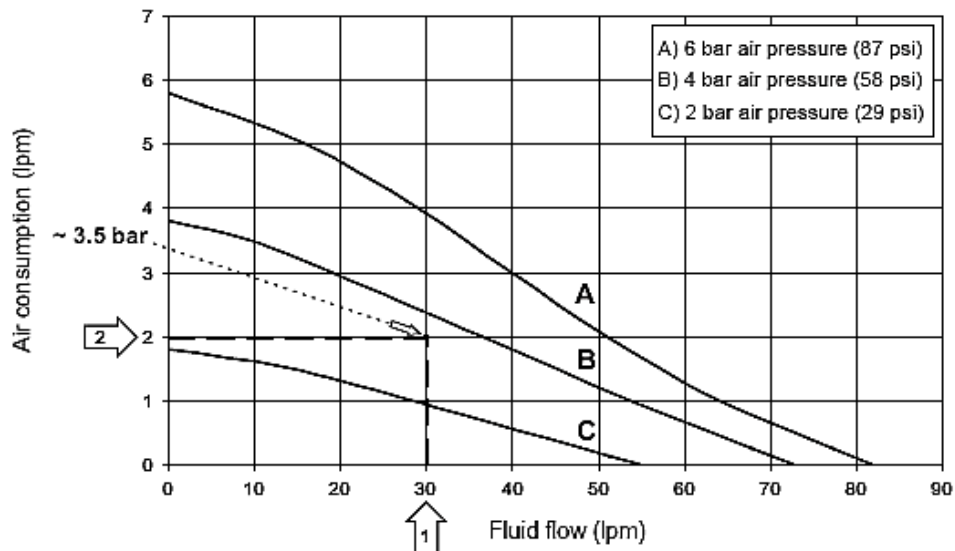

Air consumption

Again - find the required flow (30 l/min) along the horizontal axis. Go vertical to the intersection with the required air pressure (3,5 bar) and read the air consumption to the left. In the example, ~ 180 l/min.

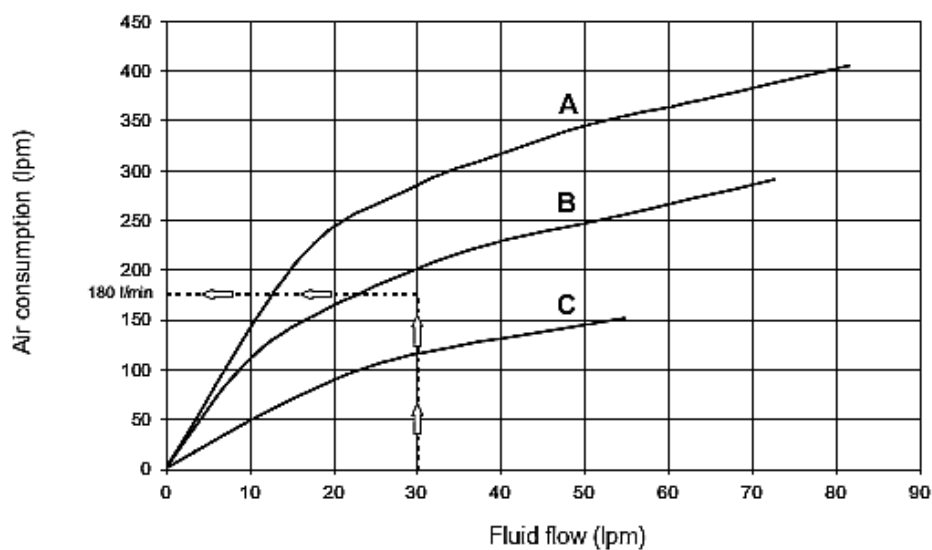



3.2.1 Reduction for viscosity AD15 - AD120

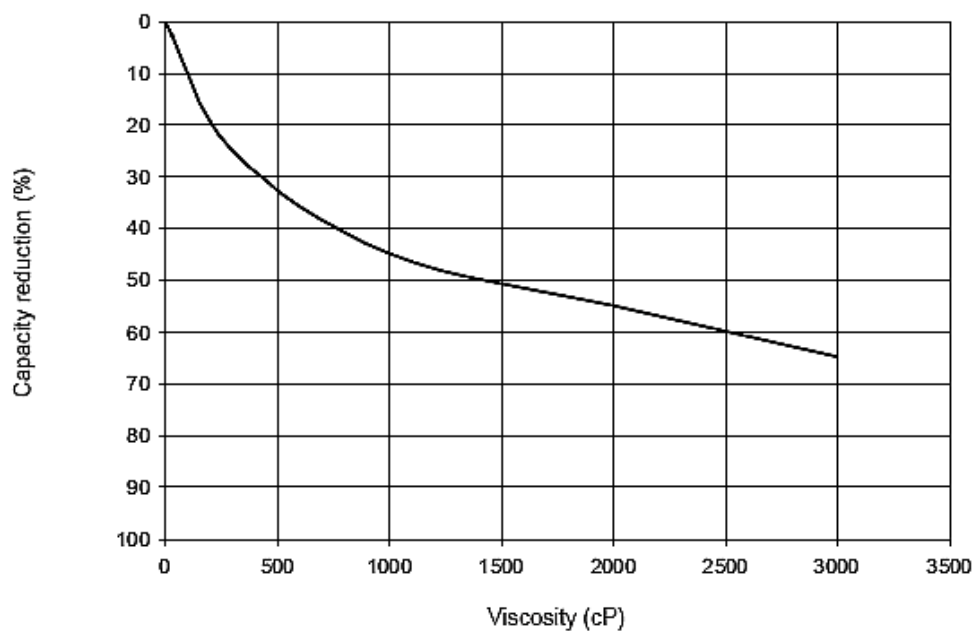

3.2.2 Reduction for suction lift AD15 - AD120

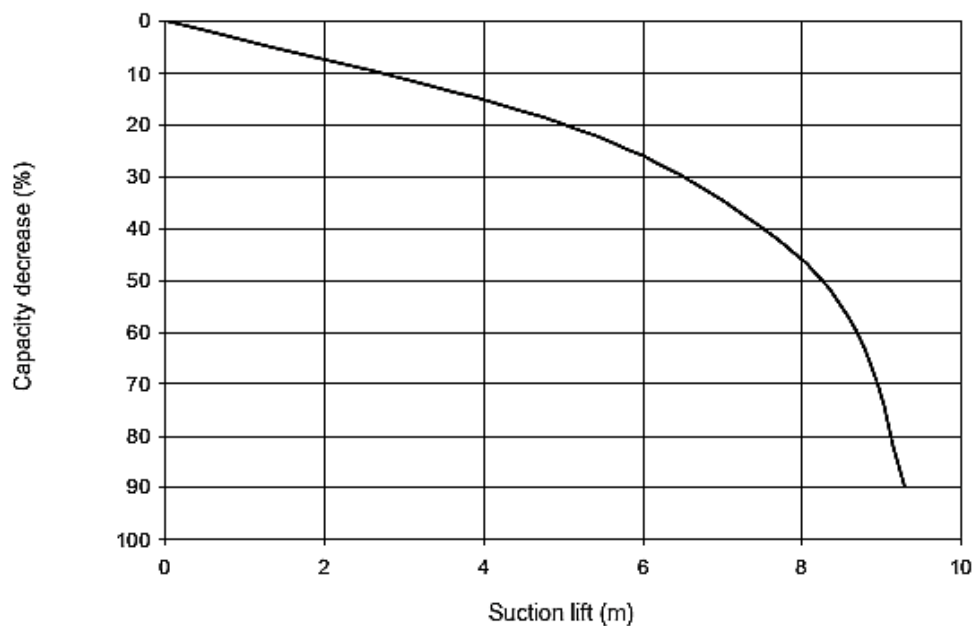



3.3 AD15

Flow / Pressure

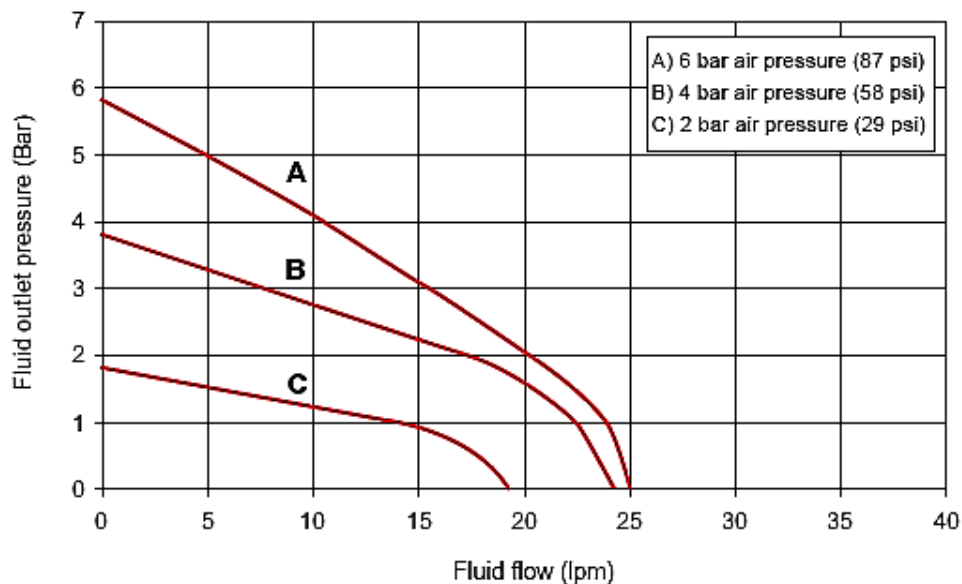

Flow & Air consumption

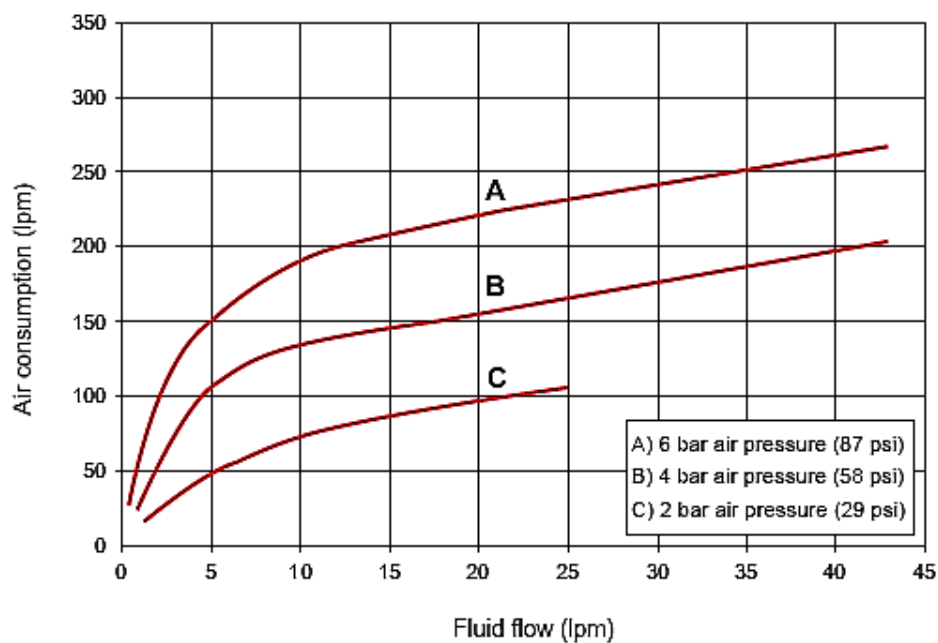



3.4 AD30

Flow / Pressure

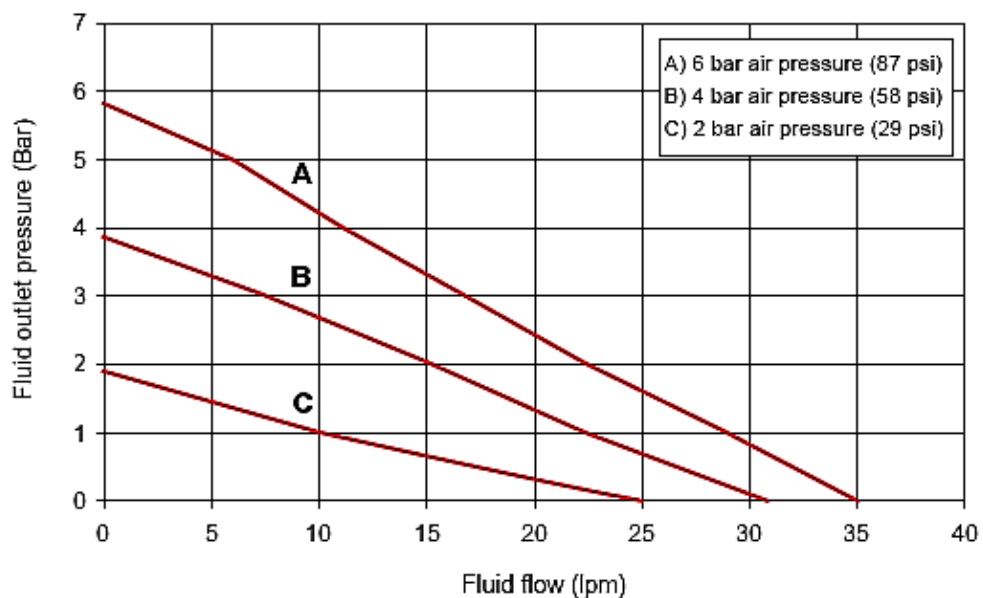

Flow & Air consumption

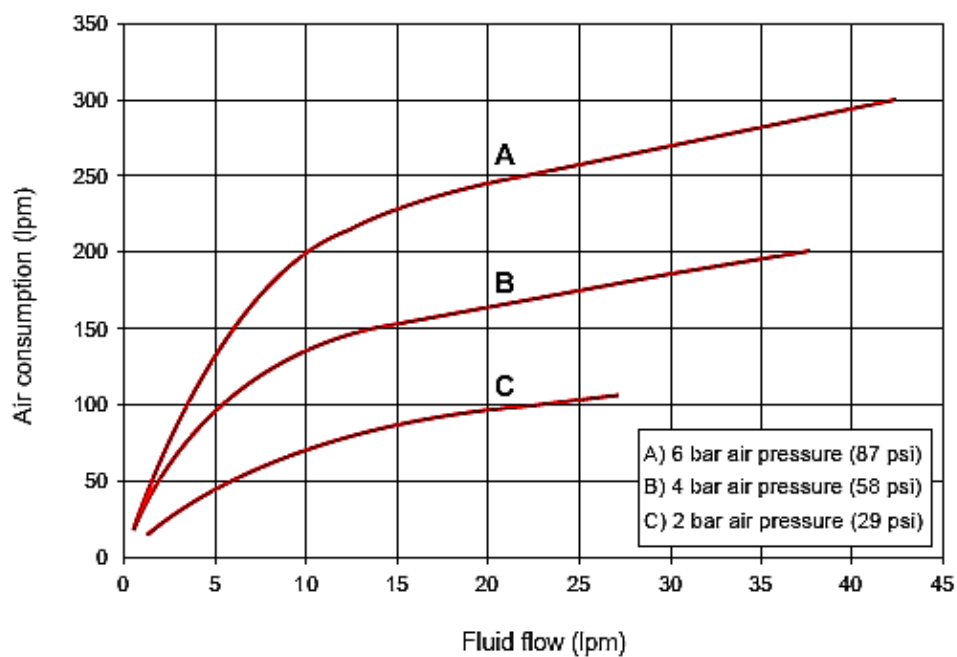



3.5 AD60

Flow / Pressure

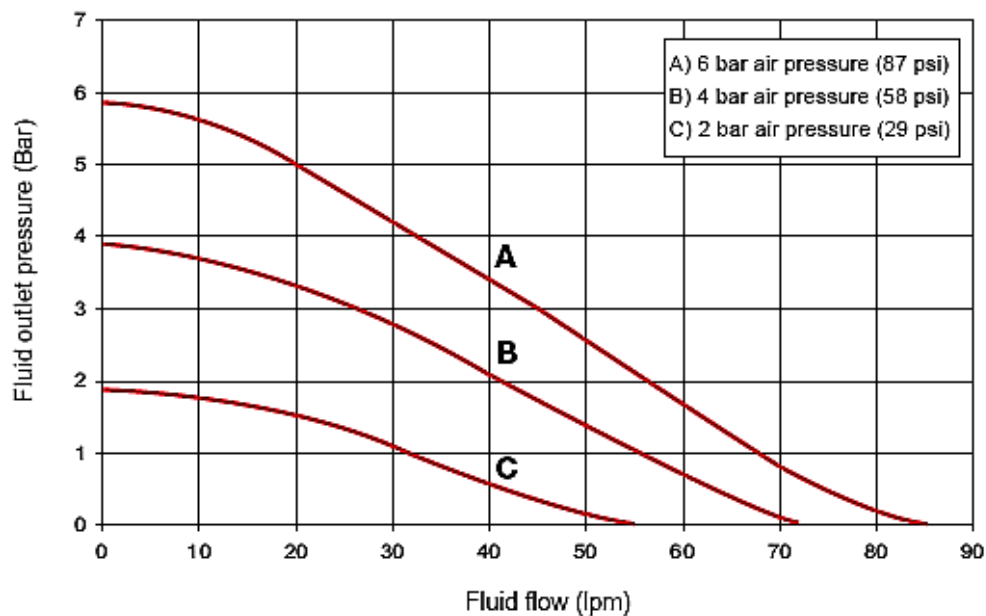

Flow & Air consumption

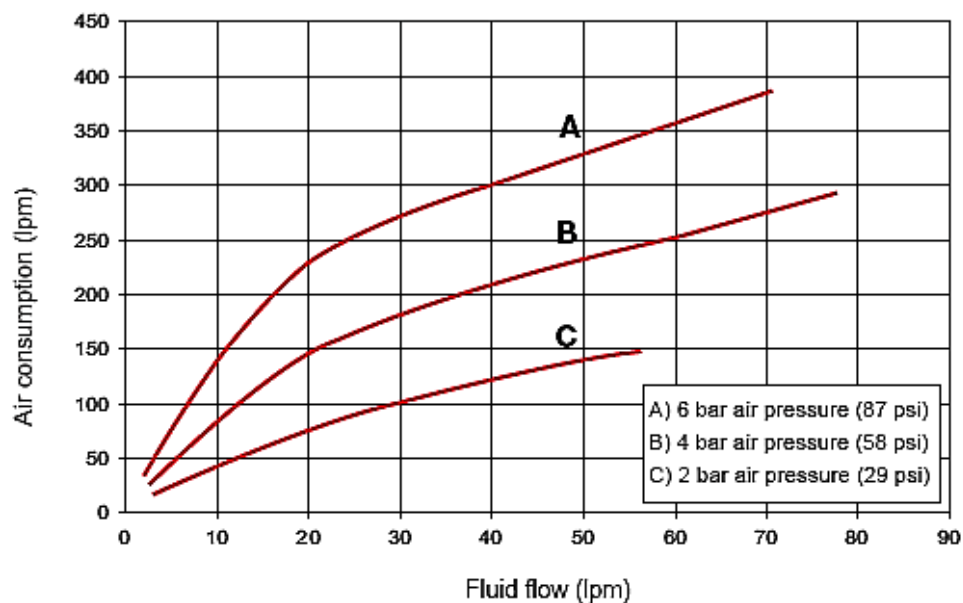



3.6 AD120

Flow / Pressure

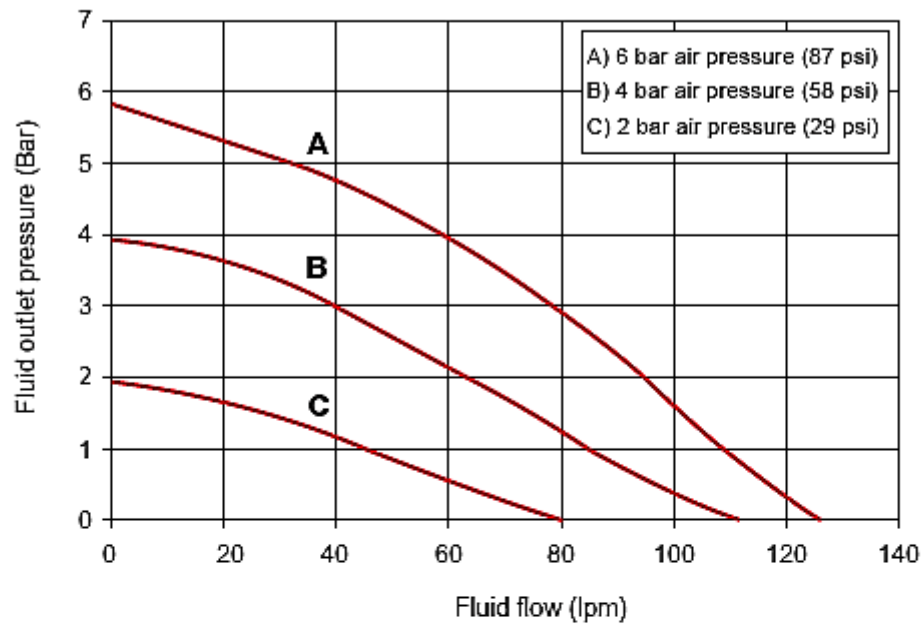

Flow & Air consumption

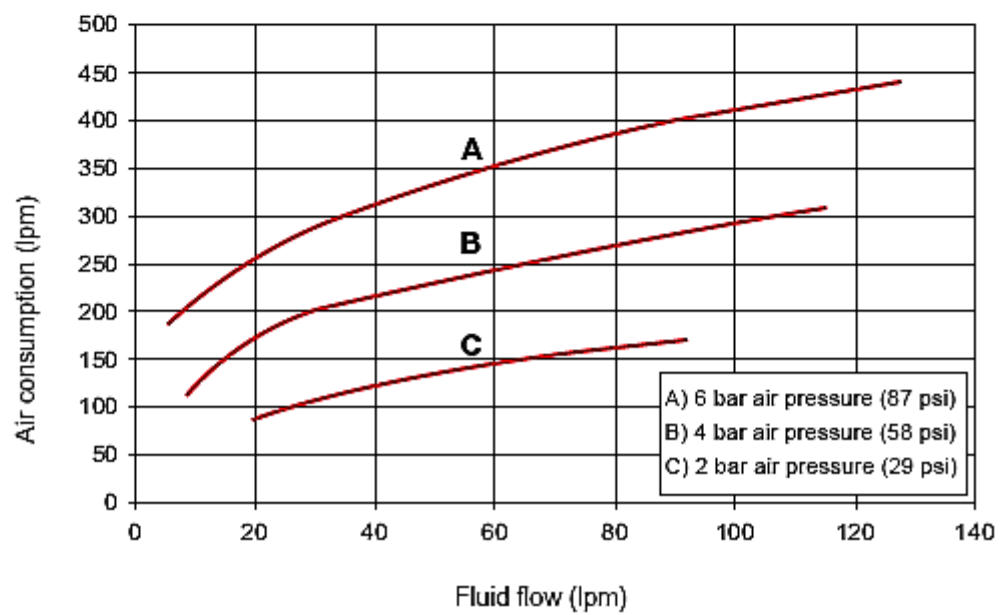

4.0 Installation

4.1 System design and installation

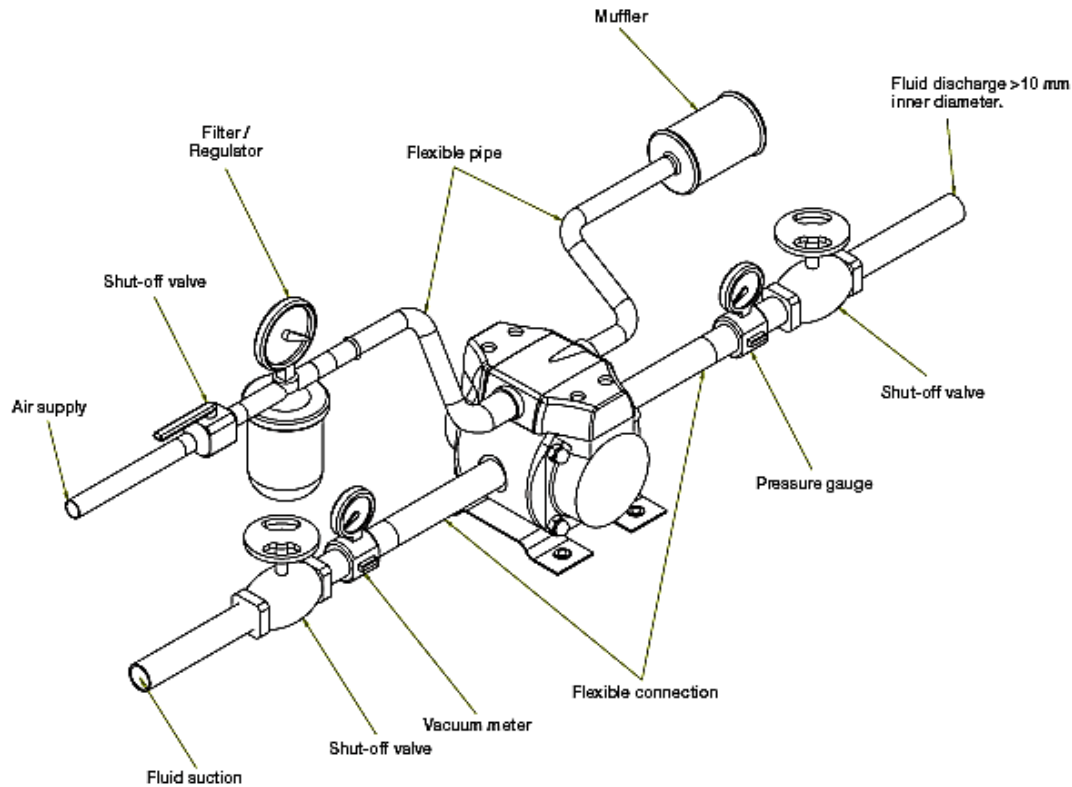

For the air connections, use an oversize air line of minimum 10 mm diameter.

When a pump is to be incorporated in a system, it is good practice to, as far as possible, minimise the length of the pipes/hoses and the number of fittings (tees, unions, bends, etc.) and restrictions. *When designing the suction lines, particular care should be taken. These should be as short and straight as possible, using a minimum of fittings to optimise a good product flow to the pump. Use a reinforced, non-collapsible hose of at least the same inner diameter as the suction port. Always consider the following when designing a system:*

Make sure that there is enough room provided around the pump to allow for routine service work, i.e. to dismantle the covers to inspect or change the diaphragms and check valves. The Liquid Flow comes with a stainless steel foot plate and rubber feet. For security reasons it is recommended to bolt the pump to a base. Thanks to the flap valves the pump can be mounted upside-down, sideways or on any of its 360-degree axis - see illustration.

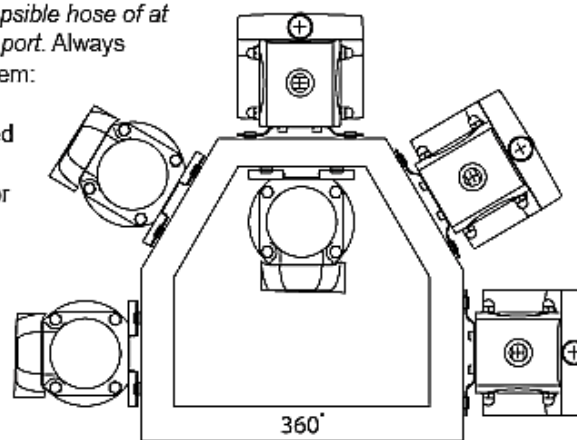



The AOFD pump should be attached to the plant piping using a flexible hose/coupling on both the intake and discharge ports of the pump. *The pump must not be used to support the pipelines.* All pipe work to and from the pump must be independently supported otherwise there is a risk of distortion of the pump components. The suction pipe or hose should be at least the diameter of the pump's inlet port or larger if a highly viscous product is being pumped. The suction hose must be of a reinforced, non-collapsible type.

By fitting an over-dimensioned (2 times the diameter of the pump discharge) flexible hose to the discharge, vibrations and/or pulsation are reduced to a minimum in the system. The hose should be 2 - 2.5 m long and can be arranged in a loop. The discharge piping should also be at least the same diameter as the pump port. By increasing the diameter of the piping the friction losses decrease.

Before using the pump for the first time, all external screws and nuts should be checked to match the given torque specifications – see picture. It is advised to check the fasteners after one day of operation and thereafter every two - three months.

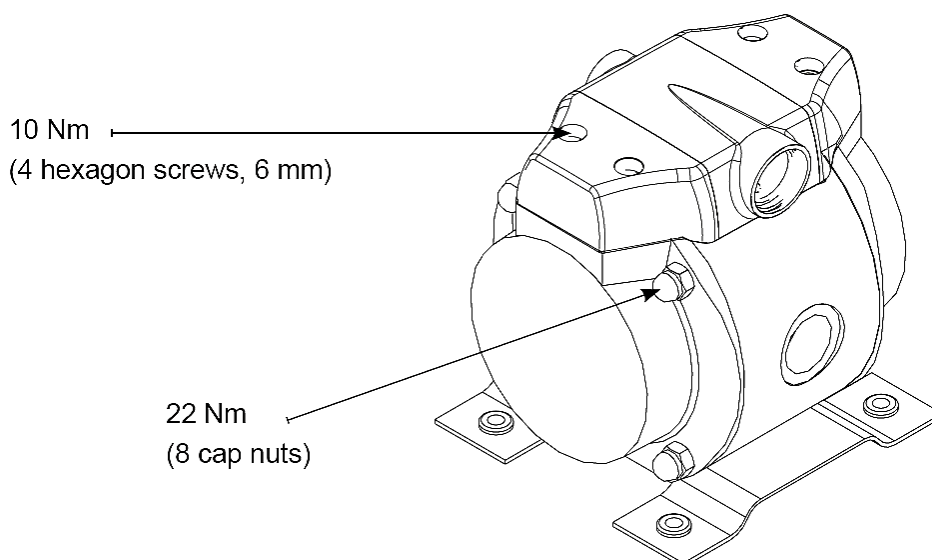

It is recommended to use a compatible, liquid sealant on all male threads. Be sure to tighten all connections firmly to avoid air or fluid leakage.

The AOFD pump can only operate in one direction and the fluid inlet is below the name plate. The arrow on the name plate shows the flow direction. The air and liquid flow is in the same direction.

Thanks to the ingenious design of the air motor (FPV - Frictionless Pivoting Valve) any type of air can be used - dry or oily, clean or dirty. Still it is recommended to install a filter/regulator combination.

4.2 Suggested pump installation

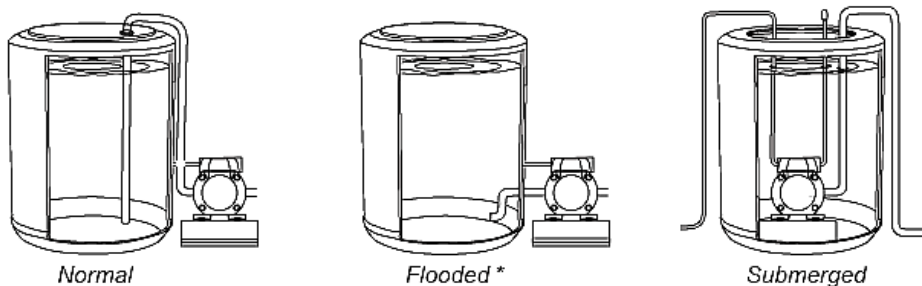

4.3 Venting exhaust air

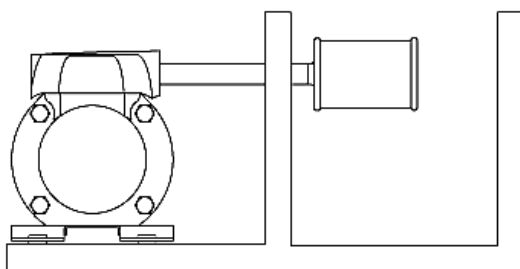

The air exhaust should be piped to an isolated container for safe disposal of the product being pumped, in the event of a diaphragm failure. This also reduces the pump noise. As shown in the illustration a larger muffler can be fitted to further reduce noise.

4.4 Before starting the pump

Ensure that the suction pipes/hoses are free from debris. It is advised to run the pump with a compatible fluid (e.g. water) prior to production start-up to ensure the system is correctly installed and there is no leakage.

* Use fixed shaft at flooded installations



4.5 How to start, operate and stop the pump

Open the fluid discharge and suction valves. Gradually increase the air pressure with the pressure regulator until the pump starts to cycle and the suction and discharge lines are filled.

Now, by adjusting the regulator, the stroking speed can be controlled, until the required flow is obtained. Adjusting of the shut-off valve in the discharge line will also effect the flow.

There are many ways to stop the pump:

- 1) Close the fluid discharge shut-off valve. The pressure built up in the discharge line will not exceed the air inlet pressure. Pump will cycle slowly but no additional liquid is entering the pump. Pump will restart as soon as the valve is opened again.
- 2) Close the air supply shut-off valve.
- 3) Reduce the air pressure with the pressure regulator so air supply pressure is less than the fluid discharge pressure.

4.6 Routine maintenance

Regular inspections are the best means for preventing unscheduled pump down time. Each pump application has a unique service requirement. To predict and prevent future maintenance problems it is advised to check the pump after a few weeks running time. After this inspection it is possible to make up a preventative maintenance schedule.

Size	Action
Diaphragms	Replace if cracks occur in the carrier rubber and/or PTFE layer. Inspection is recommended at every 15 million cycles - repeatably. Dependant of application
Muffler	Replace if clogged with impurities.
Shaft bushing	Replace if worn.
Screws/nuts	Check they are correctly tightened – see section 4.1.

5.0 Directions for disassembly and reassembly

Warning - before any maintenance or repair is attempted, shut off the compressed air line and disconnect it from the pump. Allow all air pressure to bleed from pump. Close the suction and discharge shut-off valves before disconnecting the pump. Drain pump carefully prior to disassembly

5.1 Disassembly

The only tools required to completely disassemble the AOFD pump, are:

- 2 pieces 13 mm combination spanners.
- 2 different hexagon (allen) keys, 2.5 and 5 mm.

It is also advised to use a small screwdriver to lift O-rings and rubber packings. For the reassembly a torque wrench, adjustable up to 25 Nm, is also required.

5.1.1 Diaphragms

- 1) Remove the 4 hexagon screws (32) and lift off the complete air motor (27) with the external air motor gaskets (33).
- 2) Remove the 4 cap nuts (4) on one side of the pump and separate the covers (4) from the pump housing. Now the diaphragms (5) are loose and can be inspected or replaced.

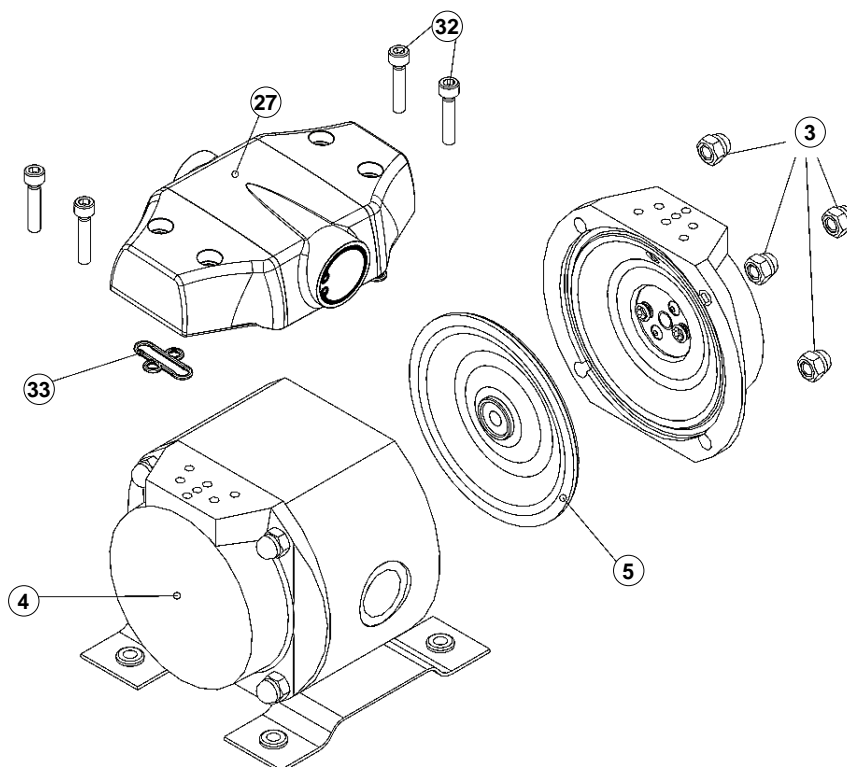

5.1. 4 Air motor

- 1) Unscrew the 4 hexagon screws (32) and remove the air-motor (27).
- 2) Remove the two air-motor gaskets (33).
- 3) Remove the CEG lockring (29) and remove the inlet insert (30).
- 4) Remove the CEG lockring (31) and remove the muffler (28).

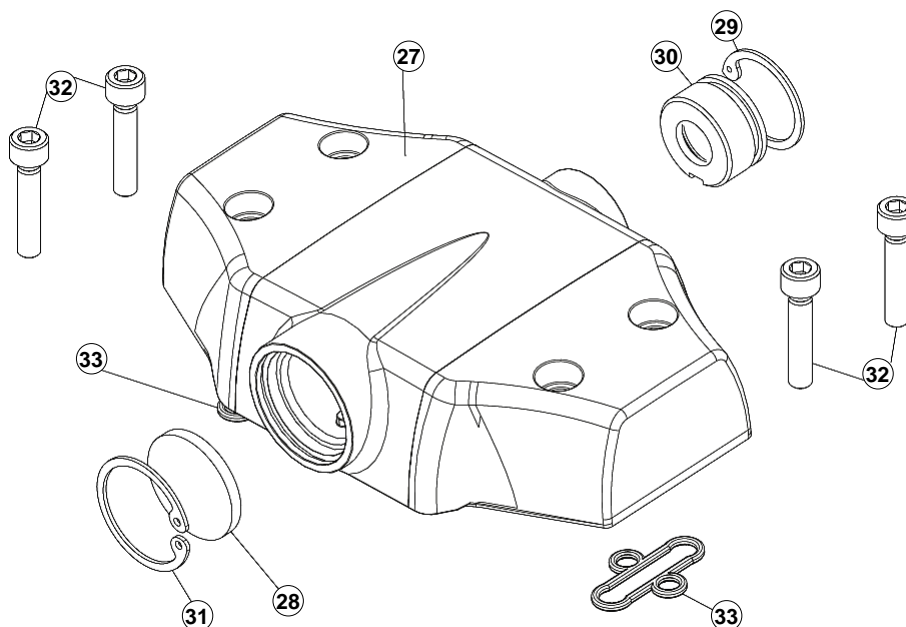

5.2 Reassembly

5.2.1 Air motor and manifolds

- 1) Fit the muffler (28) and the CEG lockring outlet (31).
- 2) Fit the inlet insert (30) and the CEG lockring inlet (29)
- 3) Fit the two airmotor gaskets firmly (33).
- 4) Tighten the 4 hexagon screws (32)

5.2.2 Covers and air distribution mechanism

- 1) Fit the O-ring (22). Put the ball (23) in place. Fit the air outlet seal (19) to the washer (18). Fit the plunge (20) and the ball seat (21).
- 2) Fit the mechanism to the seat in the cover. Check that the mechanism is tight by introducing compressed air in the outer hole (A). Push the air check valve open a few times to ensure it operates properly.

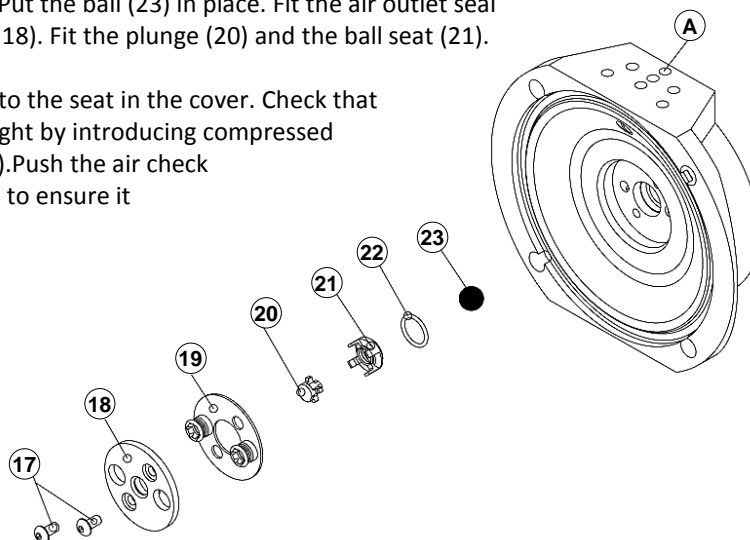

5.2.3 Pilot valve, bushing, spring and check valves

- 1) Push the Pilot valve bushing (14) in place. Fit two new PTFE O-rings (8 and 9) in the pump housing (1). Fit the inlet check valve (7) on one of the retainers (6). Push the retainer firmly in place so it snap locks into the seat.
- 2) Turn the pump housing (1). Fit the inlet check valve (7) on the other retainer. Place the outlet check valve (12) together with the opening limiter (13) in its seat and push the second retainer (6) in place.
- 3) Check the outlet check valve through the pump outlet. Screw the two retainers with the hexagon screws (11) and the self-locking nuts (10). Tighten the screws until the retainers are firmly seated. Fit the pilot valve (15) and the spring (16) (optional!).

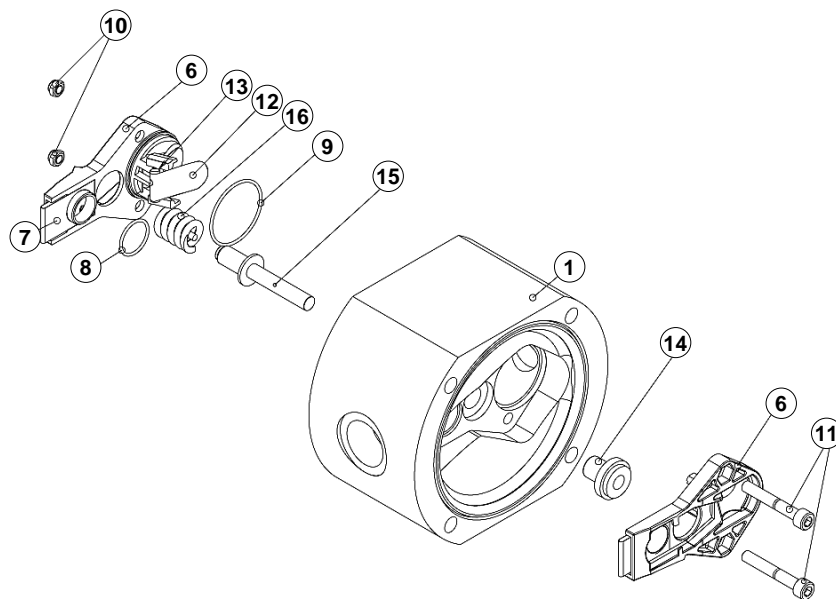

5.2.4 Diaphragms

- 1) Put the diaphragms (6) in the lids (5). The diaphragms are guided by the stud bolts so there is no risk they come off place.
- 2) Tighten the cap nuts (4) with 22 Nm.

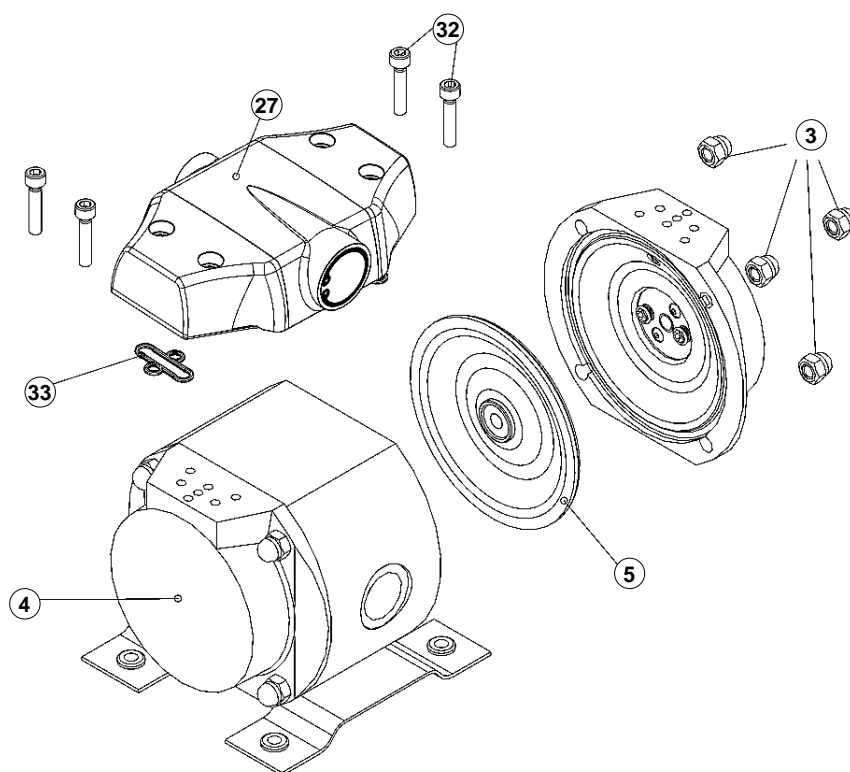

5.2.5 Air motor

- 1) Fit the complete air motor (2) with air motor gaskets (3) on top of the pump housing. Tighten the screws (1) with 10 Nm.

6.0 Dimensions and weights

Pump type:	A	B	D	E	F	G	H	I	J	K	L	M	N	O	Weight kg PP / AL
AD15	14	145	2.5	64.5	130	97,6	141	101	118	147	147	123	1/4"	3/8"	2.5 / 3.7
AD30	14	145	2.5	64.5	130	97,6	141	101	118	147	147	123	3/8"	3/8"	2.5 / 3.7
AD60	14	164	2.5	74	149	97,6	141	101	118	147	147	141	3/4"	3/8"	3.6 / 4.9
AD120	14	210	2.5	97	195	97,6	184	134	148.5	178	170	184	1.1/4"	3/8"	6.9 / 9.8

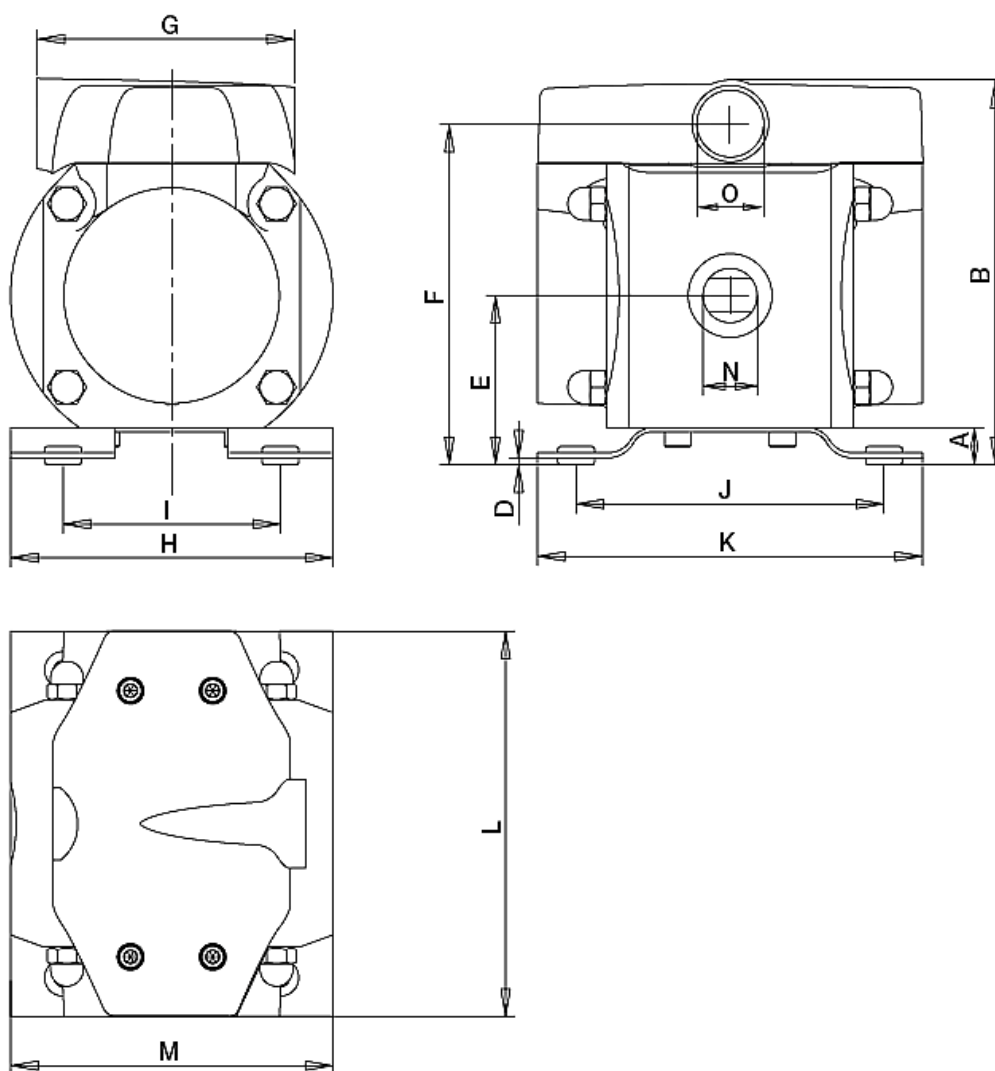

7.0 Exploded views and Part lists

7.1 Pump

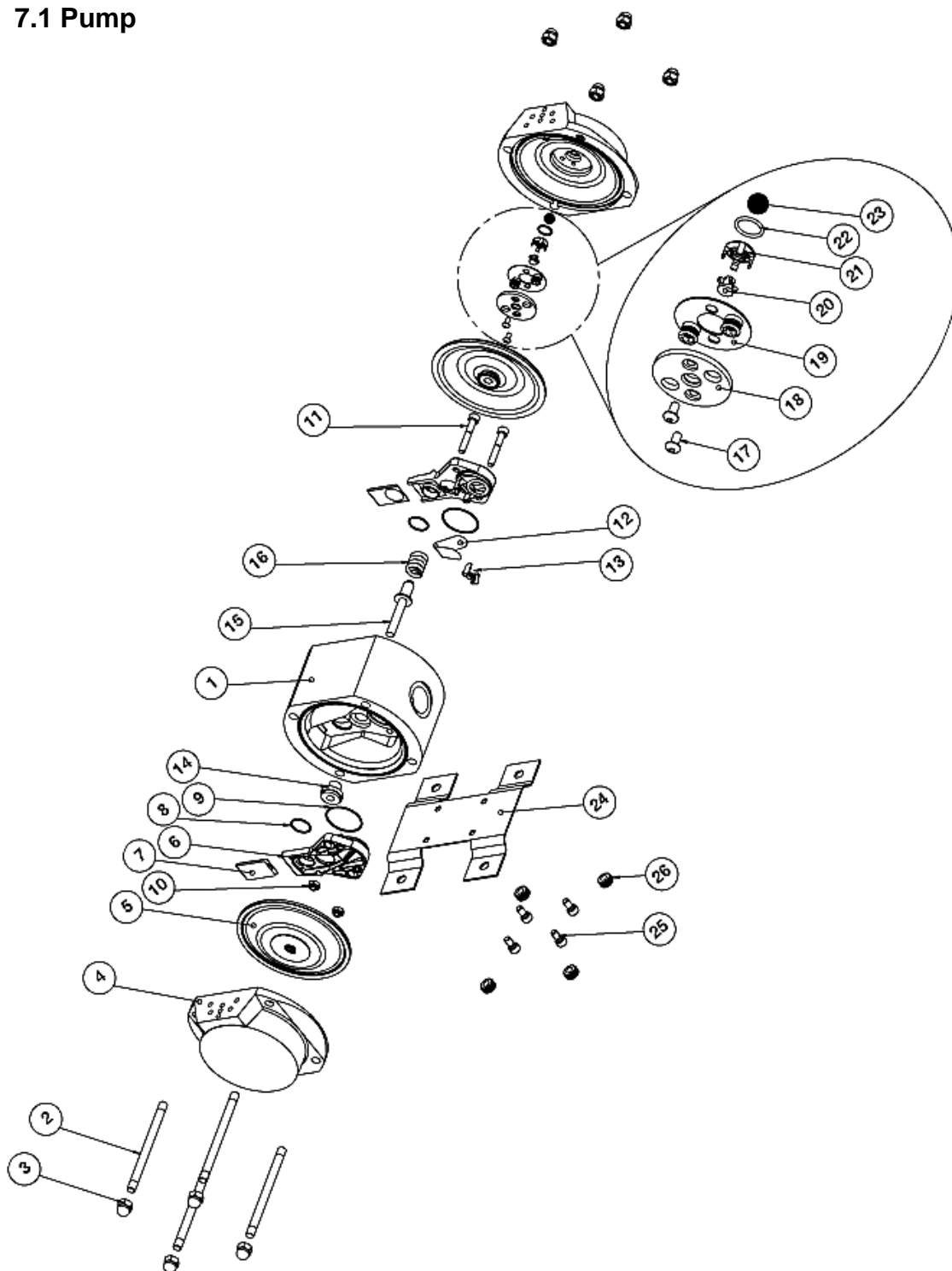



Pump part list (see section 7.1)

Pos	Description	Version	AD15 / 30	AD60	AD120
1	Pump housing, PP	PP, PX	incl. in Pump housing PP and PX kit		
	Pump housing, Al	AL, AX	incl. in Pump housing Al and AX kit		
2	Stud bolt	all	incl. in Pump housing PP/Al kits and Stud bolt kit		
3	Cap nut	all	incl. in Pump housing PP/Al kits and Stud bolt kit		
4	Lid	all	incl. in Cover kit		
5	Diaphragm, PTFE	T	incl. in Diaphragm kit		
6	Checkvalve retainer	all	incl. in Check valve kit with retainer		
7	Checkvalve, inlet	all	incl. in Check valve kit and Check valve kit with retainer		
8	PTFE, O-ring-seal	all	incl. in Check valve kit and Check valve kit with retainer		
9	PTFE, O-ring-seal	all	incl. in Check valve kit and Check valve kit with retainer		
10	Locknut	all	incl. in Check valve kit with retainer		
11	Hexagon screw	all	incl. in Check valve kit with retainer		
12	Checkvalve, outlet	all	incl. in Check valve kit and Check valve kit with retainer		
13	Opening limiter	all	incl. in Check valve kit and Check valve kit with retainer		
14	Pilot valve bushing	all	incl. in Check valve kit, Check valve kit with retainer		
15	Pilot valve	all	incl. in Pilot valve kit		
16	Pilot valve Spring	all	Optional		
17	Hexagon screw	all	incl. in Air distribution kit		
18	Air outlet Washer	all	incl. in Air distribution kit		
19	Air outlet seal	all	incl. in Air distribution kit		
20	Air outlet Plunge	all	incl. in Air distribution kit		
21	Air outlet Ball seat	all	incl. in Air distribution kit		
22	O-ring	all	incl. in Air distribution kit		
23	Air outlet Ball	all	incl. in Air distribution kit		
24	Foot plate	all	incl. in Foot plate kit		
25	Screw, Al housing	AL, AX	incl. in Foot plate kit AL		
	Screw, PP housing	PP, PX	incl. in Foot plate kit PP		
26	Rubber fot	all	incl. in Foot plate kit		

7.2 Air motor spare parts (Kits see section 7.3)

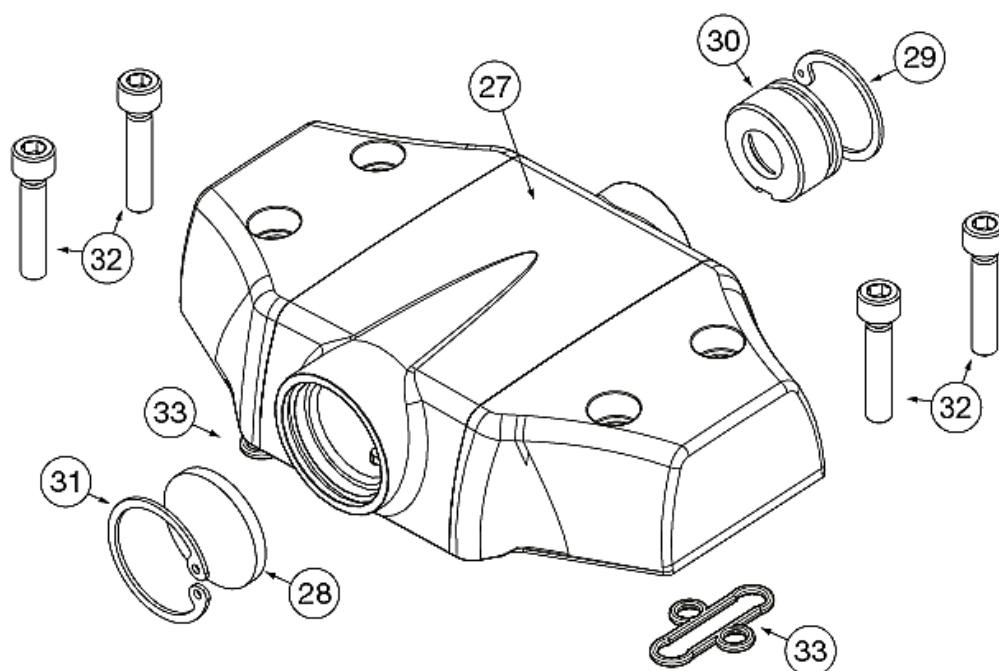

Pos	Description	Version	AD15 / 30	AD60	AD120
27	Air motor	all	Incl. in Air motor kit and Air connection kit		
28	Muffler standard	all	Incl. in Air motor kit and Muffler standard kit		
29	CEG locking inlet	all	Incl. in Air motor kit and Air connection kit		
30	Insert Inlet	all	Incl. in Air motor kit and Air connection kit		
31	CEG locking outlet	all	Incl. in Air motor kit and Muffler standard kit		
32	Hexagon screw	all	Incl. in Air motor kit		
33	Airmotor gasket external	all	Incl. in Air motor kit and Airmotor gasket kit		



1) Spare part Kits (Drawing see section 7.1)

Air connection Kit 15-120

K101-001		
Pos	Description	Qty
29	CEG Lockring Inlet	1
30	Insert Inlet	1

Air Distribution Kit 15-120

K101-010		
Pos	Description	Qty
20	Air outlet Plunge	1
18	Air Outlet Washer	1
19	Air outlet Seal	1
23	Air outlet Ball D10	1
21	Air outlet Ball seat	1
17	Screw M4x8	2
22	O-ring 12x1,5 NBR	1

Airmotor Gasket Kit 15-120

K101-020		
Pos	Description	Qty
33	Airmotor Gasket External	2

Check Valve Kit 15.30

K102-001		
Pos	Description	Qty
7	Checkvalve Inlet 15.30	2
12	Checkvalve Outlet 15.30	1
9	O-ring Teflon [18]	2
8	O-ring Teflon [19]	2
13	Opening limiter 15.30	1
14	Pilot valve Busching 15.30	1

Checkvalve Kit 60

K102-002		
Pos	Description	Qty
7	Checkvalve Inlet 60	2
12	Checkvalve Outlet 60	1
9	O-ring Teflon [18]	2
8	O-ring Teflon [19]	2
13	Opening limiter 60	1
14	Pilot valve Bushing 60	1

Checkvalve Kit 120

K102-003		
Pos	Description	Qty
7	Checkvalve Inlet 120	2
12	Checkvalve Outlet 120	1
9	O-ring Teflon [18]	2
8	O-ring Teflon [19]	2
13	Opening limiter 120	1
14	Pilot valve Bushing 120	1

Checkvalve Kit with Retainer 15.30

K102-100		
Pos	Description	Qty
7	Checkvalve Inlet 15.30	2
12	Checkvalve Outlet 15.30	1
9	O-ring Teflon [18]	2
8	O-ring Teflon [19]	2
13	Opening Limiter 15.30	1
14	Pilot valve Bushing 15.30	1
6	Checkvalve Retainer 15.30	2
11	Screw M6x45	2
10	Lock nut M6 DIN 980	2

Checkvalve Kit with Retainer 60

K102-101		
Pos	Description	Qty
7	Checkvalve Inlet 60	2
12	Checkvalve Outlet 60	1
9	O-ring Teflon [18]	2
8	O-ring Teflon [19]	2
13	Opening Limiter 60	1
14	Pilot valve Bushing 60	1
6	Checkvalve Retainer 60	2
11	Screw M6x45	2
10	Lock nut M6 DIN 980	2

Checkvalve Kit with Retainer 120

K102-102		
Pos	Description	Qty
7	Checkvalve Inlet 120	2
12	Checkvalve Outlet 120	1
9	O-ring Teflon [18]	2
8	O-ring Teflon [19]	2
13	Opening Limiter 120	1
14	Pilot valve Bushing 120	1
6	Checkvalve Retainer 120	2
11	Screw M6x45	2
10	Lock nut M6 DIN 980	2

Airmotor Kit 15.30.60

K103-001		
Pos	Description	Qty
27	Air Motor 15, 30, 60	1
28	Muffler Standard	1
29	CEG lockring Inlet	1
30	Insert Inlet	1
31	CEG lockring Outlet	1
32	Screw M6x30 A2	4
33	Air Motor Gasket External	2

Airmotor Kit 120

K103-001		
Pos	Description	Qty
27	Air Motor 120	1
28	Muffler Standard	1
29	CEG lockring Inlet	1
30	Insert Inlet	1
31	CEG lockring Outlet	1
32	Screw M6x30 A2	4
33	Air Motor Gasket External	2

Lid Kit 15.30

K104-001		
Pos	Description	Qty
4	Lid 15.30	1

Lid Kit 60

K104-001		
Pos	Description	Qty
4	Lid 60	1

Kid Kit 120

K104-001		
Pos	Description	Qty
4	Lid 120	1

Diaphragm Kit 15.30

K104-001		
Pos	Description	Qty
5	Diaphragm 15.30 Teflon	1

Diaphragm Kit 60

K104-001		
Pos	Description	Qty
5	Diaphragm 60 Teflon	1

Diaphragm Kit 120

K104-001		
Pos	Description	Qty
5	Diaphragm 120 Teflon	1



2) Spare part Kits (Drawing see section 7.1)

PumpHousing AL Kit 15 K109-001 <table border="1"> <thead> <tr> <th>Pos</th> <th>Description</th> <th>Qty</th> </tr> </thead> <tbody> <tr> <td>24</td> <td>Foot Plate</td> <td>1</td> </tr> <tr> <td>26</td> <td>Rubber Foot</td> <td>4</td> </tr> <tr> <td>25</td> <td>Screw</td> <td>4</td> </tr> </tbody> </table>	Pos	Description	Qty	24	Foot Plate	1	26	Rubber Foot	4	25	Screw	4	Pumphousing AL kit 30 K109-002 <table border="1"> <thead> <tr> <th>Pos</th> <th>Description</th> <th>Qty</th> </tr> </thead> <tbody> <tr> <td>24</td> <td>Foot plate</td> <td>1</td> </tr> <tr> <td>26</td> <td>Rubber foot</td> <td>4</td> </tr> <tr> <td>25</td> <td>screw</td> <td>4</td> </tr> </tbody> </table>	Pos	Description	Qty	24	Foot plate	1	26	Rubber foot	4	25	screw	4	Pumphousing AL kit 60 K109-003 <table border="1"> <thead> <tr> <th>Pos</th> <th>Description</th> <th>Qty</th> </tr> </thead> <tbody> <tr> <td>24</td> <td>Foot plate</td> <td>1</td> </tr> <tr> <td>26</td> <td>Rubber foot</td> <td>4</td> </tr> <tr> <td>25</td> <td>Screw</td> <td>4</td> </tr> </tbody> </table>	Pos	Description	Qty	24	Foot plate	1	26	Rubber foot	4	25	Screw	4	Pumphousing AL kit 120 K109-004 <table border="1"> <thead> <tr> <th>Pos</th> <th>Description</th> <th>Qty</th> </tr> </thead> <tbody> <tr> <td>24</td> <td>Foot Plate</td> <td>1</td> </tr> <tr> <td>26</td> <td>Rubber foot</td> <td>4</td> </tr> <tr> <td>25</td> <td>Screw</td> <td>4</td> </tr> </tbody> </table>	Pos	Description	Qty	24	Foot Plate	1	26	Rubber foot	4	25	Screw	4
Pos	Description	Qty																																																	
24	Foot Plate	1																																																	
26	Rubber Foot	4																																																	
25	Screw	4																																																	
Pos	Description	Qty																																																	
24	Foot plate	1																																																	
26	Rubber foot	4																																																	
25	screw	4																																																	
Pos	Description	Qty																																																	
24	Foot plate	1																																																	
26	Rubber foot	4																																																	
25	Screw	4																																																	
Pos	Description	Qty																																																	
24	Foot Plate	1																																																	
26	Rubber foot	4																																																	
25	Screw	4																																																	
Pilot valve Kit 15.30 K107-001 <table border="1"> <thead> <tr> <th>Pos</th> <th>Description</th> <th>Qty</th> </tr> </thead> <tbody> <tr> <td>14</td> <td>Pilot valve Bushing 15.30</td> <td>1</td> </tr> <tr> <td>15</td> <td>Pilot valve 15.30</td> <td>1</td> </tr> <tr> <td>16</td> <td>Pilot valve Spring 15.30</td> <td>1</td> </tr> </tbody> </table>	Pos	Description	Qty	14	Pilot valve Bushing 15.30	1	15	Pilot valve 15.30	1	16	Pilot valve Spring 15.30	1	Pilot valve Kit 60 K107-002 <table border="1"> <thead> <tr> <th>Pos</th> <th>Description</th> <th>Qty</th> </tr> </thead> <tbody> <tr> <td>14</td> <td>Pilot valve Bushing 60</td> <td>2</td> </tr> <tr> <td>15</td> <td>Pilot valve 60</td> <td>1</td> </tr> <tr> <td>16</td> <td>Pilot valve Spring 60</td> <td>2</td> </tr> </tbody> </table>	Pos	Description	Qty	14	Pilot valve Bushing 60	2	15	Pilot valve 60	1	16	Pilot valve Spring 60	2	Pilot valve Kit 120 K107-003 <table border="1"> <thead> <tr> <th>Pos</th> <th>Description</th> <th>Qty</th> </tr> </thead> <tbody> <tr> <td>14</td> <td>Pilot valve Bushing 120</td> <td>2</td> </tr> <tr> <td>15</td> <td>Pilot valve 120</td> <td>1</td> </tr> <tr> <td>16</td> <td>Pilot valve Spring 120</td> <td>2</td> </tr> </tbody> </table>	Pos	Description	Qty	14	Pilot valve Bushing 120	2	15	Pilot valve 120	1	16	Pilot valve Spring 120	2													
Pos	Description	Qty																																																	
14	Pilot valve Bushing 15.30	1																																																	
15	Pilot valve 15.30	1																																																	
16	Pilot valve Spring 15.30	1																																																	
Pos	Description	Qty																																																	
14	Pilot valve Bushing 60	2																																																	
15	Pilot valve 60	1																																																	
16	Pilot valve Spring 60	2																																																	
Pos	Description	Qty																																																	
14	Pilot valve Bushing 120	2																																																	
15	Pilot valve 120	1																																																	
16	Pilot valve Spring 120	2																																																	
Studbolt Kit 15, 30, 60 K108-001 <table border="1"> <thead> <tr> <th>Pos</th> <th>Description</th> <th>Qty</th> </tr> </thead> <tbody> <tr> <td>2</td> <td>Stud Bolt</td> <td>4</td> </tr> <tr> <td>3</td> <td>Cap Nuts</td> <td>8</td> </tr> </tbody> </table>	Pos	Description	Qty	2	Stud Bolt	4	3	Cap Nuts	8	Studbolt Kit 120 K108-002 <table border="1"> <thead> <tr> <th>Pos</th> <th>Description</th> <th>Qty</th> </tr> </thead> <tbody> <tr> <td>2</td> <td>Stud Bolt</td> <td>4</td> </tr> <tr> <td>3</td> <td>Cap Nuts</td> <td>8</td> </tr> </tbody> </table>	Pos	Description	Qty	2	Stud Bolt	4	3	Cap Nuts	8																																
Pos	Description	Qty																																																	
2	Stud Bolt	4																																																	
3	Cap Nuts	8																																																	
Pos	Description	Qty																																																	
2	Stud Bolt	4																																																	
3	Cap Nuts	8																																																	
PumpHousing AL Kit 15 K109-001 <table border="1"> <thead> <tr> <th>Pos</th> <th>Description</th> <th>Qty</th> </tr> </thead> <tbody> <tr> <td>1</td> <td>Pump Housing AL 15</td> <td>1</td> </tr> </tbody> </table>	Pos	Description	Qty	1	Pump Housing AL 15	1	Pumphousing AL kit 30 K109-002 <table border="1"> <thead> <tr> <th>Pos</th> <th>Description</th> <th>Qty</th> </tr> </thead> <tbody> <tr> <td>1</td> <td>Pumphousing AL 30</td> <td>1</td> </tr> </tbody> </table>	Pos	Description	Qty	1	Pumphousing AL 30	1	Pumphousing AL kit 60 K109-003 <table border="1"> <thead> <tr> <th>Pos</th> <th>Description</th> <th>Qty</th> </tr> </thead> <tbody> <tr> <td>1</td> <td>Pumphousing AL 60</td> <td>1</td> </tr> </tbody> </table>	Pos	Description	Qty	1	Pumphousing AL 60	1	Pumphousing AL kit 120 K109-004 <table border="1"> <thead> <tr> <th>Pos</th> <th>Description</th> <th>Qty</th> </tr> </thead> <tbody> <tr> <td>1</td> <td>Pumphousing AL 120</td> <td>1</td> </tr> </tbody> </table>	Pos	Description	Qty	1	Pumphousing AL 120	1																								
Pos	Description	Qty																																																	
1	Pump Housing AL 15	1																																																	
Pos	Description	Qty																																																	
1	Pumphousing AL 30	1																																																	
Pos	Description	Qty																																																	
1	Pumphousing AL 60	1																																																	
Pos	Description	Qty																																																	
1	Pumphousing AL 120	1																																																	
PumpHousing AX Kit 15 K109-100 <table border="1"> <thead> <tr> <th>Pos</th> <th>Description</th> <th>Qty</th> </tr> </thead> <tbody> <tr> <td>1</td> <td>Pump Housing AX 15</td> <td>1</td> </tr> </tbody> </table>	Pos	Description	Qty	1	Pump Housing AX 15	1	Pumphousing AX kit 30 K109-101 <table border="1"> <thead> <tr> <th>Pos</th> <th>Description</th> <th>Qty</th> </tr> </thead> <tbody> <tr> <td>1</td> <td>Pumphousing AX 30</td> <td>1</td> </tr> </tbody> </table>	Pos	Description	Qty	1	Pumphousing AX 30	1	Pumphousing AX kit 60 K109-102 <table border="1"> <thead> <tr> <th>Pos</th> <th>Description</th> <th>Qty</th> </tr> </thead> <tbody> <tr> <td>1</td> <td>Pumphousing AX 60</td> <td>1</td> </tr> </tbody> </table>	Pos	Description	Qty	1	Pumphousing AX 60	1	Pumphousing AX kit 120 K109-103 <table border="1"> <thead> <tr> <th>Pos</th> <th>Description</th> <th>Qty</th> </tr> </thead> <tbody> <tr> <td>1</td> <td>Pumphousing AX 120</td> <td>1</td> </tr> </tbody> </table>	Pos	Description	Qty	1	Pumphousing AX 120	1																								
Pos	Description	Qty																																																	
1	Pump Housing AX 15	1																																																	
Pos	Description	Qty																																																	
1	Pumphousing AX 30	1																																																	
Pos	Description	Qty																																																	
1	Pumphousing AX 60	1																																																	
Pos	Description	Qty																																																	
1	Pumphousing AX 120	1																																																	
PumpHousing PP Kit 15 K109-200 <table border="1"> <thead> <tr> <th>Pos</th> <th>Description</th> <th>Qty</th> </tr> </thead> <tbody> <tr> <td>1</td> <td>Pump Housing PP 15</td> <td>1</td> </tr> </tbody> </table>	Pos	Description	Qty	1	Pump Housing PP 15	1	Pumphousing PP kit 30 K109-201 <table border="1"> <thead> <tr> <th>Pos</th> <th>Description</th> <th>Qty</th> </tr> </thead> <tbody> <tr> <td>1</td> <td>Pumphousing PP 30</td> <td>1</td> </tr> </tbody> </table>	Pos	Description	Qty	1	Pumphousing PP 30	1	Pumphousing PP kit 60 K109-202 <table border="1"> <thead> <tr> <th>Pos</th> <th>Description</th> <th>Qty</th> </tr> </thead> <tbody> <tr> <td>1</td> <td>Pumphousing PP 60</td> <td>1</td> </tr> </tbody> </table>	Pos	Description	Qty	1	Pumphousing PP 60	1	Pumphousing PP kit 120 K109-203 <table border="1"> <thead> <tr> <th>Pos</th> <th>Description</th> <th>Qty</th> </tr> </thead> <tbody> <tr> <td>1</td> <td>Pumphousing PP 120</td> <td>1</td> </tr> </tbody> </table>	Pos	Description	Qty	1	Pumphousing PP 120	1																								
Pos	Description	Qty																																																	
1	Pump Housing PP 15	1																																																	
Pos	Description	Qty																																																	
1	Pumphousing PP 30	1																																																	
Pos	Description	Qty																																																	
1	Pumphousing PP 60	1																																																	
Pos	Description	Qty																																																	
1	Pumphousing PP 120	1																																																	
PumpHousing PX Kit 15 K109-300 <table border="1"> <thead> <tr> <th>Pos</th> <th>Description</th> <th>Qty</th> </tr> </thead> <tbody> <tr> <td>1</td> <td>Pump Housing PX 15</td> <td>1</td> </tr> </tbody> </table>	Pos	Description	Qty	1	Pump Housing PX 15	1	Pumphousing PX kit 30 K109-301 <table border="1"> <thead> <tr> <th>Pos</th> <th>Description</th> <th>Qty</th> </tr> </thead> <tbody> <tr> <td>1</td> <td>Pumphousing PX 30</td> <td>1</td> </tr> </tbody> </table>	Pos	Description	Qty	1	Pumphousing PX 30	1	Pumphousing PX kit 60 K109-302 <table border="1"> <thead> <tr> <th>Pos</th> <th>Description</th> <th>Qty</th> </tr> </thead> <tbody> <tr> <td>1</td> <td>Pumphousing PX 60</td> <td>1</td> </tr> </tbody> </table>	Pos	Description	Qty	1	Pumphousing PX 60	1	Pumphousing PX kit 120 K109-303 <table border="1"> <thead> <tr> <th>Pos</th> <th>Description</th> <th>Qty</th> </tr> </thead> <tbody> <tr> <td>1</td> <td>Pumphousing PX 120</td> <td>1</td> </tr> </tbody> </table>	Pos	Description	Qty	1	Pumphousing PX 120	1																								
Pos	Description	Qty																																																	
1	Pump Housing PX 15	1																																																	
Pos	Description	Qty																																																	
1	Pumphousing PX 30	1																																																	
Pos	Description	Qty																																																	
1	Pumphousing PX 60	1																																																	
Pos	Description	Qty																																																	
1	Pumphousing PX 120	1																																																	
Muffler Kit Standard K110-001 <table border="1"> <thead> <tr> <th>Pos</th> <th>Description</th> <th>Qty</th> </tr> </thead> <tbody> <tr> <td>31</td> <td>CEG locking Outlet</td> <td>1</td> </tr> <tr> <td>28</td> <td>Muffler Standers</td> <td>1</td> </tr> </tbody> </table>	Pos	Description	Qty	31	CEG locking Outlet	1	28	Muffler Standers	1	Muffler Kit External K110-002 <table border="1"> <thead> <tr> <th>Pos</th> <th>Description</th> <th>Qty</th> </tr> </thead> <tbody> <tr> <td>31</td> <td>Ceg locking Outlet</td> <td>1</td> </tr> <tr> <td>28</td> <td>Insert Outlet</td> <td>1</td> </tr> <tr> <td>N/A</td> <td>Muffler Extended</td> <td>1</td> </tr> </tbody> </table>	Pos	Description	Qty	31	Ceg locking Outlet	1	28	Insert Outlet	1	N/A	Muffler Extended	1	Muffler Kit External with Indicator K110-003 <table border="1"> <thead> <tr> <th>Pos</th> <th>Description</th> <th>Qty</th> </tr> </thead> <tbody> <tr> <td>31</td> <td>CEG locking Outlet</td> <td>1</td> </tr> <tr> <td>28</td> <td>Insert Outlet</td> <td>1</td> </tr> <tr> <td>N/A</td> <td>Muffler Extended w indicator</td> <td>2</td> </tr> </tbody> </table>	Pos	Description	Qty	31	CEG locking Outlet	1	28	Insert Outlet	1	N/A	Muffler Extended w indicator	2																
Pos	Description	Qty																																																	
31	CEG locking Outlet	1																																																	
28	Muffler Standers	1																																																	
Pos	Description	Qty																																																	
31	Ceg locking Outlet	1																																																	
28	Insert Outlet	1																																																	
N/A	Muffler Extended	1																																																	
Pos	Description	Qty																																																	
31	CEG locking Outlet	1																																																	
28	Insert Outlet	1																																																	
N/A	Muffler Extended w indicator	2																																																	



For drawings and positions see chapter 7.0.

Pump will not run	<ul style="list-style-type: none"> • Check there is sufficient air pressure. • Check that the emergency stop valve is open. • Check inlet air filter and muffler for debris. • Check that the suction- and discharge lines are open. • Remove the muffler/air outlet hose and check that the air motor pivot moves freely. • Open the pump and check the diaphragms, air outlet seals (pos 19) and air check valves (pos 20-23). • Check that the shaft (15) moves freely. • Check the pivoting valves bearing – seal may be worn out.
Pump does not prime	<ul style="list-style-type: none"> • Check that the suction and discharge lines are open. • Check that all suction connections are air tight. • Increase the stroking speed. • Check that the cover nuts are tightened. • Check the diaphragms (pos 5). • Check that the inlet fluid check valves (pos 7 and 12) seal to the seats. • Replace the shaft bushing (pos 14) if it is worn.
Erratic pump action/heavy pulsation	<ul style="list-style-type: none"> • Check the diaphragms (pos 5). • Check that the air motor pivot (pos 31) moves freely and that the rubber seals (pos 31 and 34) are intact. • Check the fluid check valves (pos 7 and 12). • Check that the pilot spring (16) is undamaged. • Check the air outlet seals (pos 19).
Pump runs but flow is reduced	<ul style="list-style-type: none"> • Check that the suction and discharge lines are open. • Check that all suction connections are air tight. • Check for possible cavitation. Slow pump speed down to match the viscosity (thickness) of the fluid. • Open the pump and check the diaphragms (pos 5) and the fluid check valves (pos 12 and 7). • If the Pilot bushing (pos 14) is worn the internal slip increases and flow decreases - change the bushing. • Check that the air channels are free from debris.
Fluid comes out of the air exhaust	<ul style="list-style-type: none"> • Check for diaphragm rupture.
Air bubbles in the fluid	<ul style="list-style-type: none"> • Check that all suction connections are air tight. • Check for diaphragm rupture.



Albin Pump SAS

Z.A de Fontgrave267
40 Montboucher
France
Tel +33 (0) 4 75 90 92 92
Fax +33 (0) 4 75 90 92 40
info@albinpump.fr
www.albinpump.fr

Albin Pump AB

Ålegårdsgatan 1
S-431 50 Mölndal
Sweden
Tel +46 (0) 31 701 38 30
Fax +46 (0) 31 22 14 37
info@albinpump.se
www.albinpumps.se

Albin Europe BV

Platinastraat 53-1
7554 NC Hengelo
Netherlands
Tel. +31 (0) 547 292 175
info@albin-europe.com
www.albin-europe.com

For more information about our worldwide locations, approvals, certifications, and local representatives, please visit www.albinpump.com.

Albin Pump reserves the right to incorporate our latest design and material changes without notice or obligation. Design features, materials of construction and dimensional data, as described in this bulletin, are provided for your information only and should not be relied upon unless confirmed in writing.

Certified drawings are available upon request.

© 2010 Albin Pump