

A large, stylized graphic of a green leaf or blade, curved from the top left towards the bottom right, framing the central text.

ALBIN ALH
HOSE PUMP

ALBIN PUMP ALH – HOSE PUMPS

Albin Pump ALH is a hose pump of the latest design. We have combined the best available materials with smart design solutions in order to maximise running time and minimise service.

Two shoes mounted on a moving wheel compress successively a reinforced rubber hose that contains a fluid to be pumped. The motion of the shoes compressing the rubber against the pump housing creates continuous suction at the inlet of the pump and

pushes the fluid to the outlet of the pump. The sealed pump casing contains a lubricant that reduces friction of the shoes moving over the rubber hose. The pumped fluid is in contact only with the interior of the rubber hose, thus permitting the pumping of a wide variety of reactive fluids.

This pump summarizes what we at Albin Pump want to achieve: better pump solutions for our customers.

ADVANTAGES

- No Mechanical seal.
- Self priming up to 9m manometric lift.
- Damage-free continuous dry running.
- Perfect volumetric flow.
- Reversible flow for back-flushing lines.
- High discharge pressure up to 15 Bars.
- Easy maintenance, only the hose suffers wear.
- For abrasive, corrosive, sensitive or viscous fluids.
- Nuts and bolts in stainless steel parts
- Casing and reducer mounting by close coupling with seal to eliminate risk of fluid in the reducer and minimize service.
- Practical hose fitting

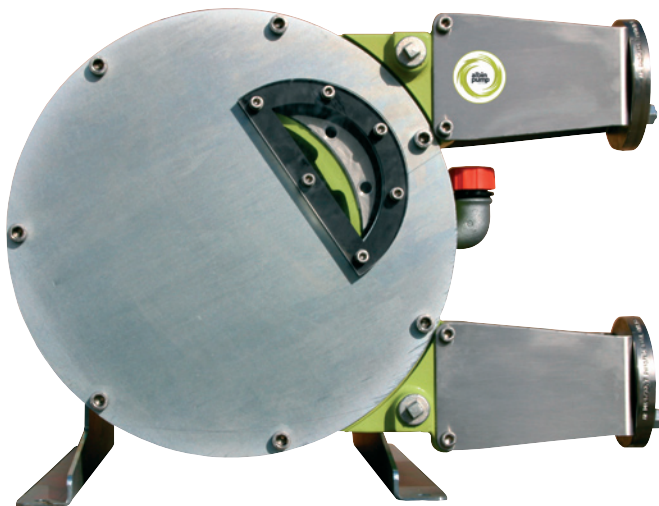

EXPERIENCED NEWTHINKER

The ALH hose pump is in many ways the future of pumping. The ALH series pump is a fantastically simple pump with a wide range, up to 150m³/h and 15 bars, that can handle most fluids in most applications.

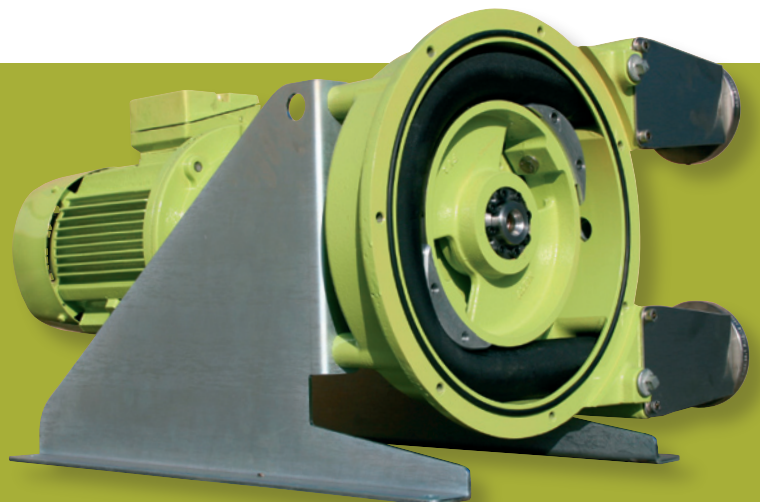

EXPERIENCED NEWTHINKER

The ALH pump is very easy to use and maintain and therefore addresses what we at Albin Pump see as two of the key customer issues:

The need to lower costs

This is done by using a pump having no valves, shaft seals, pistons, stators or rotating elements in the fluid. Taking away the risk of leaks, blockages, corrosion and wear on mechanical parts and therefore reduces maintenance cost.

The need to reduce downtime

The Albin ALH Hose Pump is virtually maintenance free and can continuously run dry. One of the key issues in today's industries is to reduce downtime in every process. The ALH series is a pump with only one wearing part and only one part in contact with the fluid, the hose. The ALH series is designed to make hose changes as fast as possible.

The ALH pump provides versatility and trouble-free pumping of abrasive slurries, corrosive acids, gaseous, shear-sensitive and viscous fluids or fluids with a high specific gravity. There is no possible contamination of the fluid to be pumped because it only comes in contact with the inner hose.

No other type of positive displacement pump has this unique quality.

ALBIN PUMP HOSE

We only work with high quality compounded rubbers, reinforced with 2 to 6 individual layers of braided nylon and with an outer layer made to strict tolerances to ensure perfect compression.

Our unique hose characteristics last approximately 30% longer than other hoses on the market and also fits the majority of other hose pumps.

Albin ALH Hose construction:

- Inner liner
- 2 to 6 reinforcement layers depending on size
- Cover

For the hose liner 3 materials are available to suit the diversity of the pumped fluids:

NR (natural rubber)	Abrasive fluids
NBR (Buna)	Oily fluids
EPDM	Acid & corrosive fluids

* NR hose has a life span which is Double than EPDM and Triple than NBR. (Depending of fluid)



TYPICAL APPLICATIONS

CERAMIC (ceramic slips, mould filling, press filters).

MINING & QUARRIES (sludge up to 60000 Cps, clay slurry up to 800g/l, lead sulfate, pyrite slurry. SABX, thickener underflow, flocculants & reagent feed, cyanide metering, activated Carbon, Acid Slurry.

WATER TREATMENT (lime liquor, flocculate dispersion, sludge and slurries). **BUILDING INDUSTRY** (liquid or fibrous mortar, liquid plaster, light concrete).

CHEMICAL INDUSTRY (acid, alcohol, detergent pumping, etc.) **NUCLEAR** (contaminated slurries and mud, ammonium dioxide, uranyl nitrate). **FOOD INDUSTRY** (tomato sauce, mashed potatoes, gelatin, beer slurries, fish past, olive oil). **PAINT** (water base and acrylic paint, pigments, wall coating). **FILTER PRESS** (filling and pressing). **PAPER INDUSTRY** (latex, slurries, kaolin). Glue, liquid salt, seed fertilizer, etc.)

ALH 10 - 20

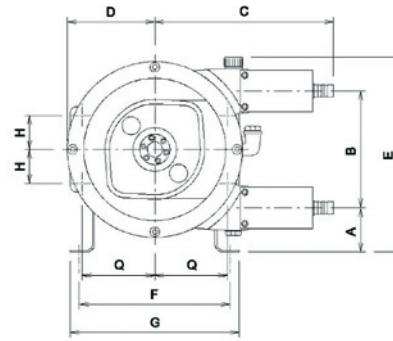
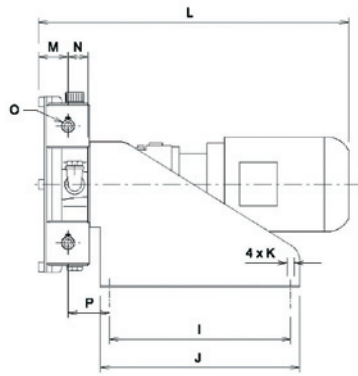

ALH 25 - 40

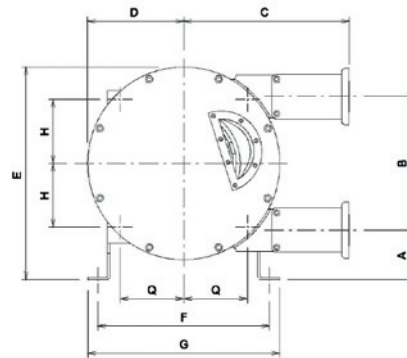
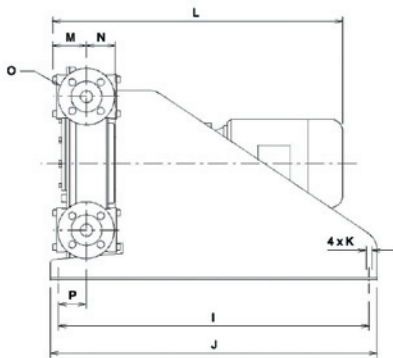

ALH 50 - 125

ALHX 40 & 80

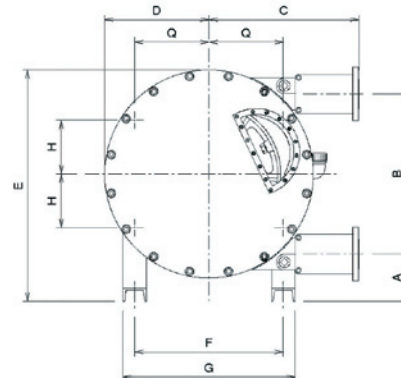
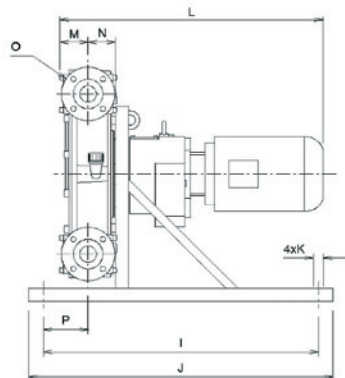

Dimensions

* hose bard connections

TYPE	A	B	C	D	E	F	G	H	I	J	K	L	M	N	O	P	Q
ALH 10	103,5	115	226	95	256	220	240	33,5	260	280	4xø9	-	46,5	26	ø16 *	56	81,25
ALH 15	73	193	296	145	322	250	280	51,75	300	330	4xø13	-	49	33,5	ø20 *	68,8	124,75
ALH 20	73	193	296	145	322	250	280	51,75	300	330	4xø13	-	49	33,5	ø25 *	68,8	124,75
ALH 25	95	262	355,5	190	416	311	351	110	560	600	4xø13	-	65	79	DN25 PN16	61	110
ALH 32	122,5	330	435,5	238	525,5	426	476	157,75	770	810	4xø13	-	83	71	DN32 PN16	109	157,75
ALH 40	122,5	330	435,5	238	525,5	426	476	157,75	770	810	4xø13	-	83	71	DN40 PN16	109	157,75
ALHX 40	110	430	400	291	616	340	420	170	850	950	4xø19	-	75	88	DN40 PN16	87	170
ALH 50	164,5	554	517,5	360	801,5	513	593	186,5	950	1050	4xø19	-	94,5	98	DN50 PN16	152	256,5
ALH 65	164,5	554	517,5	360	801,5	513	593	186,5	950	1050	4xø19	-	94,5	98	DN65 PN16	152	256,5
ALH 80	154	748	604	473	1004	580	680	290	1150	1250	4xø19	-	129	133	DN80 PN16	117	290
ALHX 80	262	876	803	55	1320	690	830	345	1300	1400	4xø27	-	140,5	145	DN80 PN16	210	345
ALH 100	300	1040	887	685	1680	820	960	410	1900	2000	4xø27	-	149	220	DN100 PN16	295	410
ALH 125	263,5	1273	1038	785	1750	1000	1140	500	1900	2000	4xø27	-	300	232	DN125 PN16	660	500

FLOW RATE (L/h)

TYPE	20 RPM	40 RPM	60 RPM	80 RPM	100 RPM
ALH 10	30	60	90	120	150
ALH 15	100	200	300	400	500
ALH 20	170	340	500	670	850
ALH 25	400	800	1 200	1 600	2 000
ALH 32	750	1 500	2 250	3 000	
ALH 40	1 170	2 340	3 510		
ALHX 40	1 600	3 200	4 800		
ALH 50	3 500	7 000	10 500		
ALH 65	4 600	9 200	13 800		
ALHX 80	11 000	22 000			

TYPE	10 RPM	20 RPM	30 RPM	40 RPM
ALH 80	7 000	14 000	21 000	28 000
ALH 100	12 000	24 000	36 000	48 000
ALH 125	22 000	44 000	66 000	

 Intensive use (L/h)

 Intermitent use (L/h)

ALBIN PUMP ALHS SERIES

For customers who require a long shaft technology, Albin Pump has also developed the ALHS series. These pumps are equipped with a removable bearing case for easy maintenance and can be converted into a close coupling ALH type pump at any time.

OPTIONS

- Twinhead pump
- Several pump bodies in line driven by the same gear motor
- Special mounting (inlet, outlet, coupling, cover etc.) is available on request
- Pump rollers without lubricant are optional
- Pumps can be equipped with hose rupture detector and revolution counter

Any other pumping requirements can be considered

How to use the curves:

- 1 Select the required flow. This gives you the required pump speed.
- 2 Move upwards to the calculated discharge pressure.
- 3 Move to the left for the installed motor power.
- 4 Determine the fluid's max. temperature.
- 5 Move to the left to the calculated discharge pressure.
- 6 Move downwards to determine your maximum allowed pump speed for the fluids temperature.

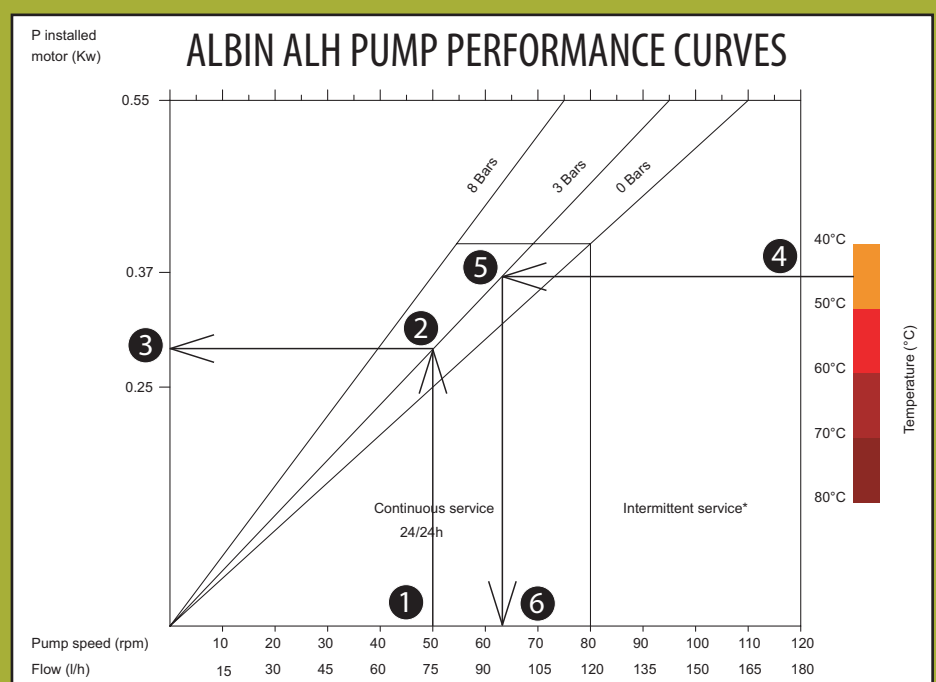

ALBIN ALH PUMP PERFORMANCE CURVES

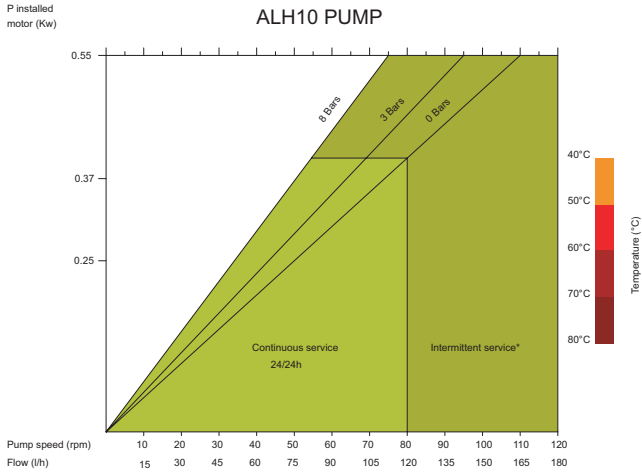

*Intermittent use is 2hrs max. continuous duty followed by 1hr stop.

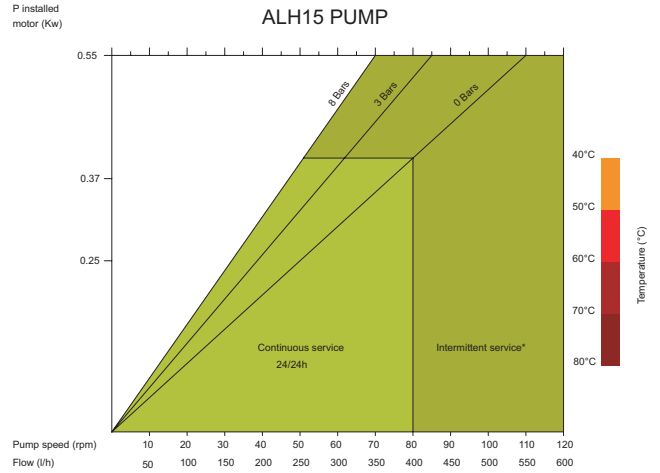

*Intermittent use is 2hrs max. continuous duty followed by 1hr stop.

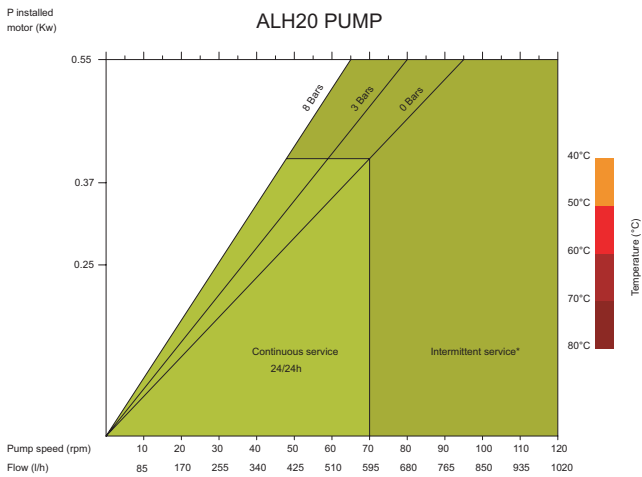

*Intermittent use is 2hrs max. continuous duty followed by 1hr stop.

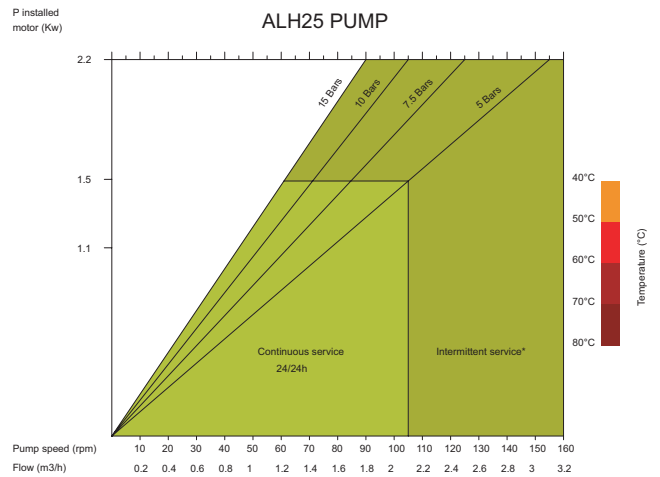

*Intermittent use is 2hrs max. continuous duty followed by 1hr stop.

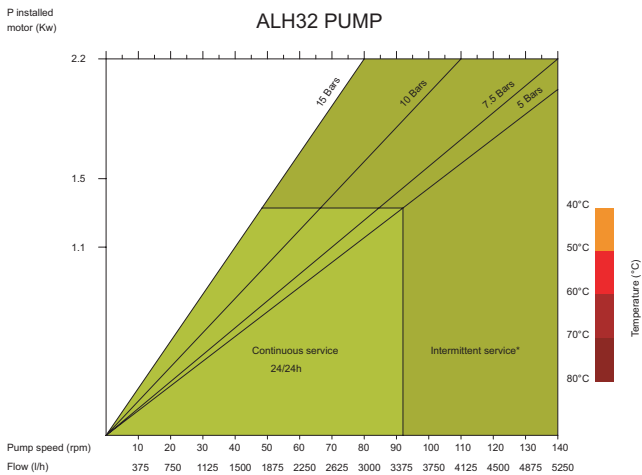

*Intermittent use is 2hrs max. continuous duty followed by 1hr stop.

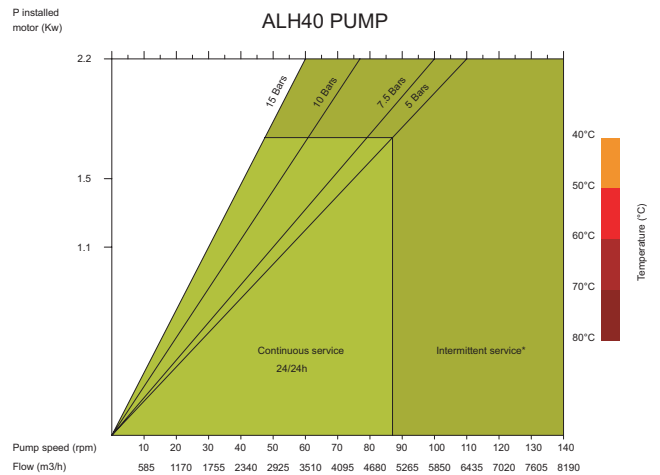

*Intermittent use is 2hrs max. continuous duty followed by 1hr stop.

ALBIN ALH PUMP PERFORMANCE CURVES

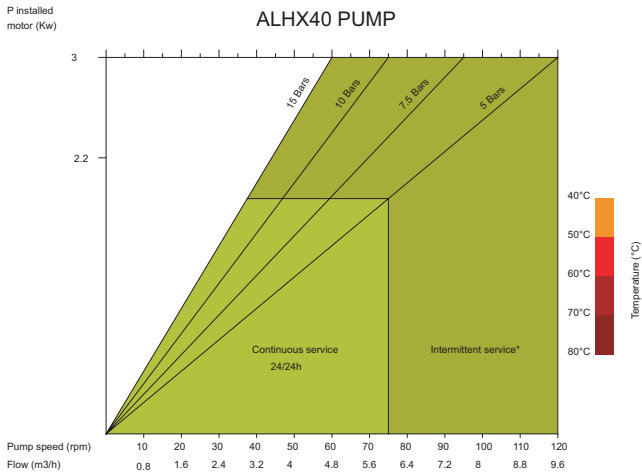

*Intermittent use is 2hrs max. continuous duty followed by 1hr stop.

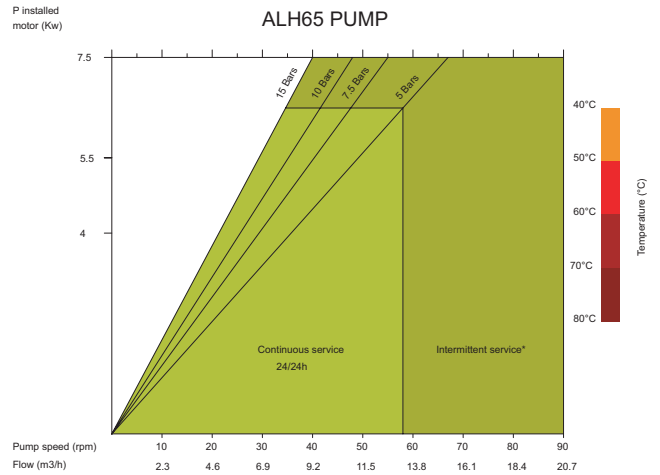

*Intermittent use is 2hrs max. continuous duty followed by 1hr stop.

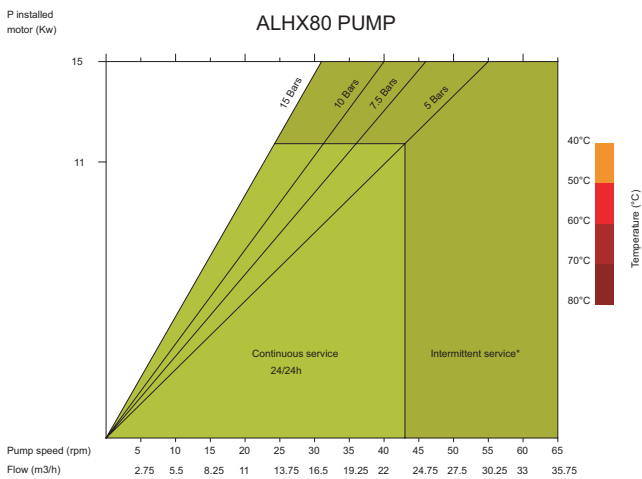

*Intermittent use is 2hrs max. continuous duty followed by 1hr stop.

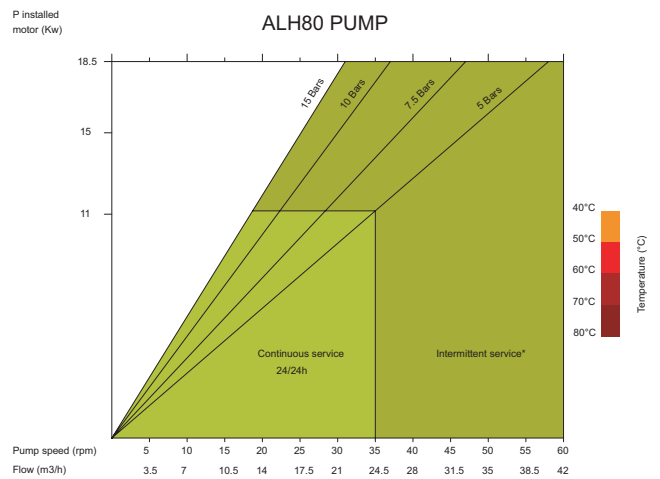

*Intermittent use is 2hrs max. continuous duty followed by 1hr stop.

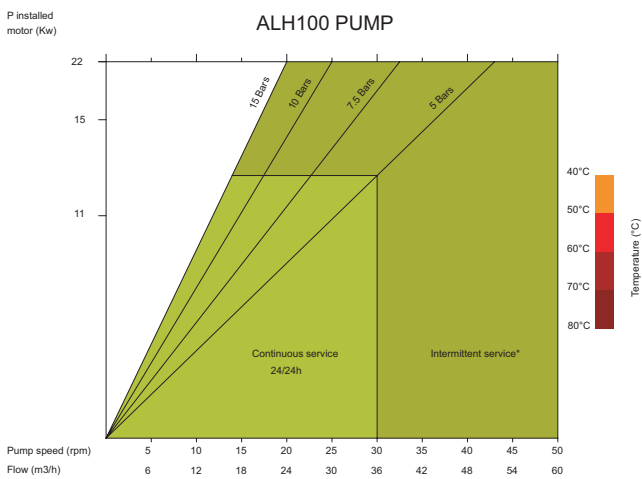

*Intermittent use is 2hrs max. continuous duty followed by 1hr stop.

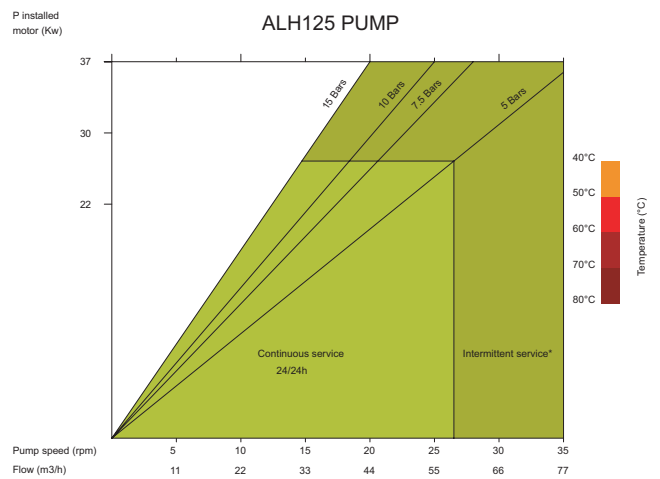

*Intermittent use is 2hrs max. continuous duty followed by 1hr stop.



Albin Pump SAS
ZAC de Fontgrave
26740 Montboucher sur Jabron
France
Tel +33 (0) 4 75 90 92 92
Fax +33 (0) 4 75 90 92 40
info@albinpump.fr
www.albinpump.fr

Albin Pump AB (Headoffice)
Ålegårdsgatan 1
S-431 50 Mölndal
Sweden
Tel +46 (0)31 701 38 36
Fax +46 (0)31 22 14 37
info@albinpump.se
www.albinpump.se